

UpRight

POWERED ACCESS



TM12
WORK PLATFORM

SERVICE & PARTS MANUAL

TM 12

Serial Numbers 50211 – Current

ENGLISH

When contacting UpRight for service or parts information, be sure to include the MODEL and SERIAL NUMBERS from the equipment nameplate. Should the nameplate be missing, the SERIAL NUMBER is also stamped on top of the chassis above the front axle pivot.

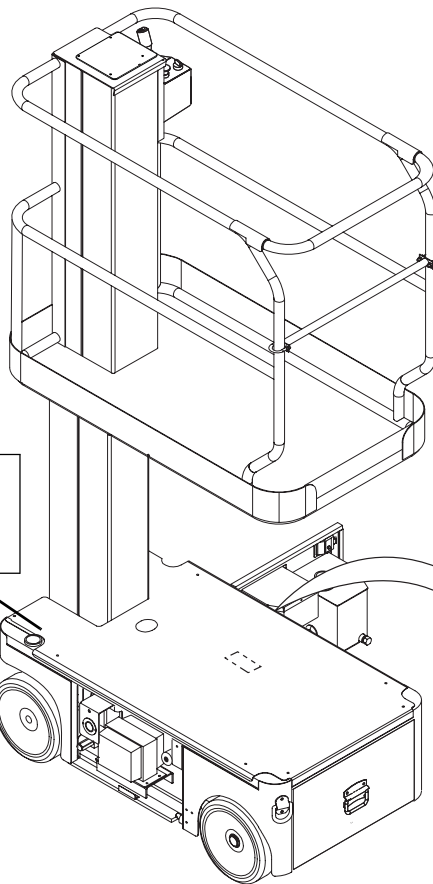

Stamped Serial Number
Estampille de numéro de série
Eingestanzte Seriennummer

UpRight		VIGO CENTRE WASHINGTON TYNE & WEAR, UK.	CE
MODEL	TM12	SERIAL No.	
MAX. PLATFORM HEIGHT	3.73m	UNLADEN WEIGHT	780 Kg
MAX. PLATFORM LOAD	227 Kg = 2 Persons Indoor + Equipment 1 Persons Outdoor		
MAX. LATERAL FORCE	400N Indoor 200N Outside	MAX. WIND SPEED	12.5 m/s
MAX. CHASSIS INCLINATION	2°	BATTERY VOLTAGE	24V
MAX. GRADEABILITY	25%	CHARGER INPUT VOLTAGE	110/220V
MAX. FORWARD SPEED	1.0 m/s	NOMINAL POWER	3kW
CAUTION: ONLY TRAINED & AUTHORISED PERSONNEL MAY USE THIS MACHINE—CONSULT OPERATORS MANUAL BEFORE USE. THIS PLATFORM IS NOT ELECTRICALLY INSULATED 505049-000			

UpRight
POWERED ACCESS

www.upright.com

TM12 SEVICE AND PARTS MANUAL

PART NUMBER : 505115-001 (10-06)

SERIAL No. 50211

FOREWORD

HOW TO USE THIS MANUAL

This manual is divided into six sections.

SECTION 1 INTRODUCTION

General description and machine specifications.

SECTION 2 OPERATION AND SPECIFICATIONS

Information on how to operate the work platform and how to prepare it for operation.

SECTION 3 MAINTENANCE

Preventative maintenance and service information.

SECTION 4 TROUBLESHOOTING

Causes and solutions to typical problems.

SECTION 5 SCHEMATICS

Schematics and valve block diagram with description and location of components. Large schematic drawings may be located in the back of the manual.

SECTION 6 ILLUSTRATED PARTS BREAKDOWN

Complete parts lists with illustrations. Large parts drawings may be located in the back of the manual.

SPECIAL INFORMATION

DANGER

Indicates an imminently hazardous situation which, if not avoided, will result in severe injury or death.

WARNING

Indicates a potentially hazardous situation which, if not avoided, could result in severe injury or death.

CAUTION

Indicates a potentially hazardous situation which, if not avoided, may result in minor or moderate injury.

NOTE: Gives helpful information.

WORKSHOP PROCEDURES

All information contained in this manual is based on the latest product information available at the time of printing. We reserve the right to make changes at any time without notice. No part of this publication may be reproduced, stored in retrieval system, or transmitted, in any form by any means, electronic, mechanical, photocopying, recording, or otherwise, without the prior written permission of the publisher. This includes text, figures, and tables.

CAUTION

Detailed descriptions of standard workshop procedures, safety principles and service operations are not included. Note that this manual does contain warnings and cautions against some specific service methods that could cause personal injury, or could damage a machine or make it unsafe. Please understand that these warnings cannot cover all conceivable ways in which service, whether or not recommended by UpRight, might be done, or of the possible hazardous consequences of each conceivable way, nor could UpRight investigate all such ways. Anyone using service procedures or tools, whether or not recommended by UpRight must satisfy themselves thoroughly that neither personal safety nor machine safety will be jeopardized. When in doubt, contact your local distributor or UpRight.

INTRODUCTION

1.1 INTRODUCTION

PURPOSE

The purpose of this service and parts manual is to provide instructions and illustrations for the operation and maintenance of the TM12 manufactured by UpRight Powered Access.

SCOPE

The manual includes procedures for proper operation, maintenance, adjustment, and repair of the TM12 as well as recommended maintenance schedules and troubleshooting.

1.2 GENERAL DESCRIPTION

The TM12 consists of the platform, controller, elevating assembly, power module, control module, and chassis.

! WARNING !

DO NOT use the work platform without guardrails properly assembled and in place.

Figure 1-1: TM12 Work Platform

PLATFORM

The platform has a reinforced steel floor, 1.11 m (43.75 inch) high guardrails with midrail, 6 inch (152 mm) toeboards, and an entrance gate at the rear of the platform.

PLATFORM CONTROLLER

The platform controller contains the controls to operate the machine. It is located at the front of the platform. A complete explanation of control functions can be found in Section 2.

ELEVATING ASSEMBLY

The platform is raised and lowered by the elevating assembly. The hydraulic pump, driven by an electric motor, powers the cylinder. Solenoid operated valves control raising and lowering.

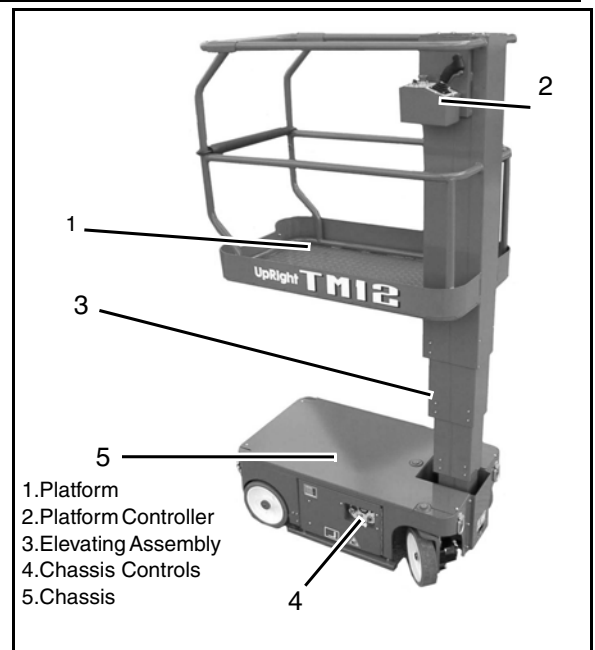

CHASSIS

The chassis is a structural frame that supports all the components of the TM12 work platform. The platform is raised and lowered using a scissors mechanism. Lift is achieved using a single stage cylinder.

PURPOSE OF EQUIPMENT

The objective of the work platform is to provide a quickly deployable, self-propelled, variable height work platform to elevate personnel and materials to overhead work areas.

2. OPERATION MANUAL

WARNING

All personnel shall carefully read, understand and follow all safety rules and operating instructions before operating or performing maintenance on any UpRight Powered Access aerial work platform.

Safety Rules

Electrocution Hazard

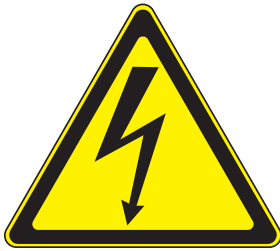

THIS MACHINE IS NOT INSULATED!

Tip Over Hazard

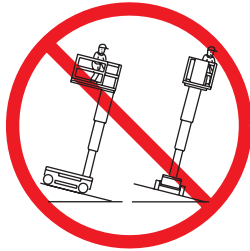

NEVER elevate the platform or drive the machine while elevated unless the machine is on a firm, level surface.

Collision Hazard



NEVER position the platform without first checking for overhead obstructions or other hazards.

Fall Hazard

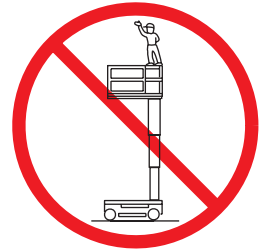

NEVER climb, stand, or sit on platform guardrails or midrail.

USE OF THE AERIAL WORK PLATFORM: This aerial work platform is intended to lift persons and his tools as well as the material used for the job. It is designed for repair and assembly jobs and assignments at overhead workplaces (ceilings, cranes, roof structures, buildings etc.). All other uses of the aerial work platform are prohibited!

THIS AERIAL WORK PLATFORM IS NOT INSULATED! For this reason it is imperative to keep a safe distance from live parts of electrical equipment!

Exceeding the specified permissible maximum load **is prohibited!** See "Platform Capacity" on page 4 for details.

The use and operation of the aerial work platform as a lifting tool or a crane **is prohibited!**

NEVER exceed the manual force allowed for this machine. See "Manual Force" on page 4 for details.

DISTRIBUTE all platform loads evenly on the platform.

NEVER operate the machine without first surveying the work area for surface hazards such as holes, drop-offs, bumps, curbs, or debris; and avoiding them.

OPERATE machine only on surfaces capable of supporting wheel loads.

NEVER operate the machine when wind speeds exceed this machine's wind rating. See "Beaufort Scale" on page 4 for details.

IN CASE OF EMERGENCY push EMERGENCY STOP switch to deactivate all powered functions.

IF ALARM SOUNDS while platform is elevated, STOP, carefully lower platform. Move machine to a firm, level surface.

Climbing up the railing of the platform, standing on or stepping from the platform onto buildings, steel or prefab concrete structures, etc., **is prohibited!**

Dismantling the entry gate or other railing components **is prohibited!** Always make certain that the entry gate is closed and securely locked!

It is prohibited to keep the entry gate in an open position when the platform is raised!

To extend the height or the range by placing of ladders, scaffolds or similar devices on the platform **is prohibited!**

NEVER perform service on machine while platform is elevated without blocking elevating assembly.

INSPECT the machine thoroughly for cracked welds, loose or missing hardware, hydraulic leaks, loose wire connections, and damaged cables or hoses before using.

VERIFY that all labels are in place and legible before using.

NEVER use a machine that is damaged, not functioning properly, or has damaged or missing labels.

To bypass any safety equipment **is prohibited** and presents a danger for the persons on the aerial work platform and in its working range.

NEVER charge batteries near sparks or open flame. Charging batteries emit explosive hydrogen gas.

Modifications to the aerial work platform **are prohibited** or permissible only at the approval by **UpRight Powered Access**.

AFTER USE, secure the work platform from unauthorized use by turning the keyswitch off and removing key.

CONTENTS

Introduction	3
General Description	3
Special Limitations	4
Platform Capacity	4
Manual Force	4
Beaufort Scale	4
Controls and Indicators	5
Pre-Operation Safety Inspection	5
System Function Inspection	6
Operation	7
Travel With Platform Lowered	7
Steering	7
Elevating Platform	7
Travel With Platform Elevated	7
Lowering Platform	7
Emergency Lowering	8
Parking Brake Release	8
After Use Each Day	8
Transporting the Machine	9
By Crane	9
By Forklift	9
By Truck	9
Maintenance	10
Blocking the Elevating Assembly	10
Installation	10
Removal	10
Hydraulic Fluid	10
Check Hydraulic Fluid	10
Battery Maintenance	11
Battery Charging	11
Inspection and Maintenance Schedule	12
Daily Preventative Maintenance Checklist	13
Specifications	14

INTRODUCTION

This manual covers all models of the TM12 Aerial Work Platform. This manual must be stored on the machine at all times.

Read, understand and follow all safety rules and operating instructions before attempting to operate the machine.

GENERAL DESCRIPTION

1. Platform

⚠ WARNING ⚠

DO NOT use the maintenance platform without guardrails properly assembled and in place

2. Entry Bar

3. Elevating Mast

4. Platform Controls

5. Manual Case

6. Electrical Box

7. Hydraulic Reservoir

8. Level Sensor

9. Battery Tray

10. Emergency Lowering Valve

11. Battery Charger

12. Drive Relief Valve

13. Charger Outlet Plug

Figure 1: TM12 Series

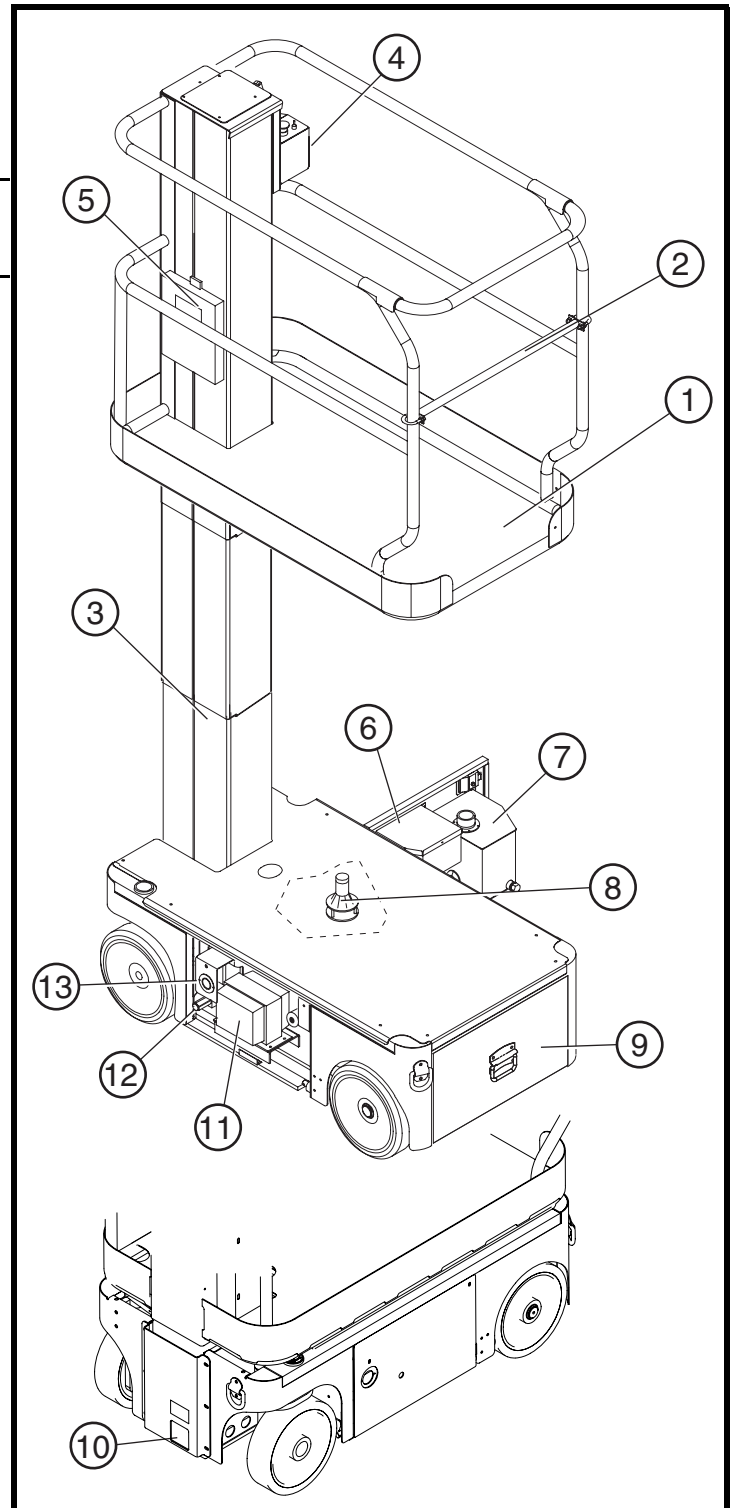

SPECIAL LIMITATIONS

Travel with the platform raised is limited to creep speed range.

Elevating the platform is limited to firm, level surfaces only.

! DANGER !

The elevating function shall ONLY be used when the work platform is level and on a firm surface.

The work platform is NOT intended to be driven over uneven, rough, or soft terrain.

PLATFORM CAPACITY

The maximum platform capacity for the TM12 is 227 kg (500 lbs). Two people may occupy the platform indoors, while only one may occupy the platform outdoors.

! DANGER !

DO NOT exceed the maximum platform capacity or the platform occupancy limits for this machine.

MANUAL FORCE

Manual force is the force applied by the occupants to objects such as walls or other structures outside the work platform.

The maximum allowable manual force is limited to 200 N (45 lbs.) of force per occupant, with a maximum of 400 N (90 lbs.) for two occupants.

! DANGER !

DO NOT exceed the maximum amount of manual force for this machine.

BEAUFORT SCALE

Never operate the machine when wind speeds exceed 12.5m/s (28mph) [Beaufort scale 6].

BEAUFORT RATING	WIND SPEED				GROUND CONDITIONS
	m/s	km/h	ft/s	mph	
3	3,4~5,4	12,25~19,4	11.5~17.75	7.5~12.0	Papers and thin branches move, flags wave.
4	5,4~8,0	19,4~28,8	17.75~26.25	12.0~18	Dust is raised, paper whirls up, and small branches sway.
5	8,0~10,8	28,8~38,9	26.25~35.5	18~24.25	Shrubs with leaves start swaying. Wave crests are apparent in ponds or swamps.
6	10,8~13,9	38,9~50,0	35.5~45.5	24.5~31	Tree branches move. Power lines whistle. It is difficult to open an umbrella.
7	13,9~17,2	50,0~61,9	45.5~56.5	31.-38.5	Whole trees sway. It is difficult to walk against the wind.

CONTROLS AND INDICATORS

The operator shall know the location of each control and indicator and have a thorough knowledge of the function and operation of each before attempting to operate the unit.

Figure 2: Controls and Indicators

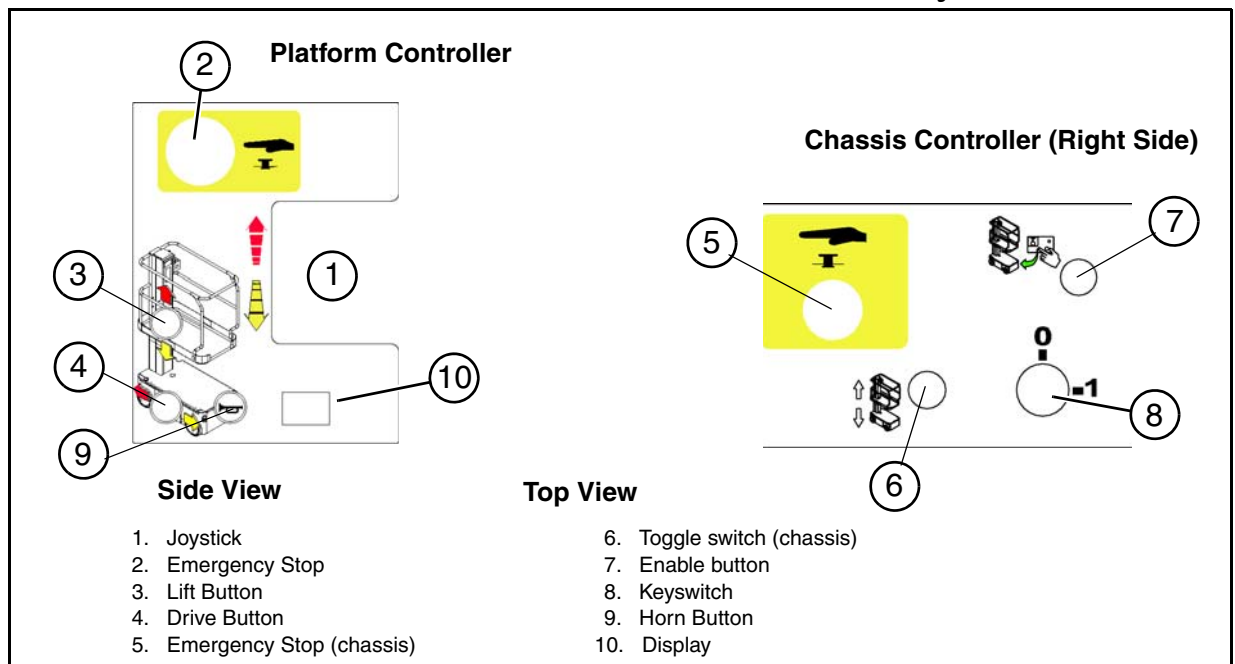

PRE-OPERATION SAFETY INSPECTION

NOTE: Carefully read, understand and follow all safety rules, operating instructions, labels and National Safety Instructions/Requirements. Perform the following steps each day before use.

1. Open the Chassis Door and inspect for damage, fluid leaks or missing parts.
2. Check the level of the hydraulic fluid with the platform fully lowered. Open the Chassis Door and remove the reservoir cap, fluid should be visible on the dipstick. Add recommended hydraulic fluid if necessary. See "Specifications" on page 14.
3. Check that the fluid level in the batteries is correct. See "Battery Maintenance" on page 11.
4. Verify that the batteries are charged.
5. Check that the A.C. extension cord has been disconnected from the chassis outlet.
6. Check that all guardrails are in place and all fasteners are properly tightened.
7. Inspect the machine thoroughly for cracked welds and structural damage, loose or missing hardware, hydraulic leaks, damaged control cable and loose wire connections.

SYSTEM FUNCTION INSPECTION

Refer to Figure 1 and Figure 2 for the locations of various controls and indicators.

⚠ WARNING ⚠

STAND CLEAR of the work platform while performing the following checks.

Before operating the machine, survey the work area for surface hazards such as holes, drop-offs, bumps and debris.

Check in **ALL** directions, including above the work platform, for obstructions and electrical conductors.

Protect the control console cable from possible damage while performing checks.

1. Move the machine, if necessary, to an unobstructed area to allow for full elevation.
2. Turn the Chassis and Platform Emergency Stop Switches ON by pulling the buttons out.
3. Turn the Chassis Key Switch to ON.
4. Push the Chassis Lift Switch to the UP position and fully elevate the platform.
5. Visually inspect the mast assembly for damage or erratic operation. Check for missing or loose parts.
6. Verify that the depression mechanism supports have rotated into position under the machine.
7. Check Level Sensor operation:
 - a. Open the door.
 - b. Push and hold the sensor off of level.
 - c. Push the Chassis Lift Switch to the UP position.
 - The alarm should sound, and the platform should not lift.
 - d. Close and latch the door.
8. Partially lower the platform by pushing the Chassis Lift Switch to DOWN, and check the operation of the audible lowering alarm.
9. Check the Chassis Emergency Lowering Valve for proper operation (see Figure 4):
 - a. Open the valve by pulling the knob out.
 - b. Once the platform is fully lowered, close the valve by releasing the knob.
10. Push the Chassis Emergency Stop Switch down to the OFF position. All machine functions should be disabled. Pull out the Chassis Emergency Stop Switch to resume.
11. Mount the platform.
12. Check that the route is clear of persons, obstructions, holes and drop-offs, is level and capable of supporting the wheel loads.
13. After mounting platform, lower the bar across the entrance.
14. Select DRIVE mode.
15. While depressing the Interlock Switch, slowly position the Control Lever to FORWARD then REVERSE to check for speed and directional control. The farther you push or pull the Control Lever from center the faster the machine will travel.
16. Push the Steering Switch RIGHT then LEFT to check for steering control.
17. Push the Platform Emergency Stop Switch down to the OFF position. All machine functions should be disabled. Pull out the Platform Emergency Stop Switch to resume.

Figure 3: Level Sensor Location

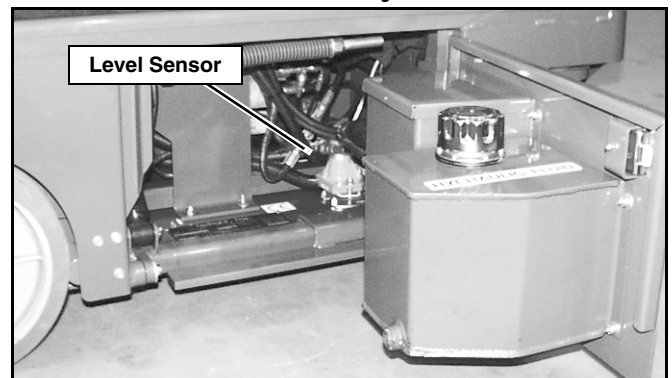

OPERATION

Before operating the machine, ensure that the Pre-Operation Safety Inspection has been completed and that any deficiencies have been corrected. **Never operate a damaged or malfunctioning machine.** The operator must be thoroughly trained on this machine.

TRAVEL WITH PLATFORM LOWERED

1. Check that the route is clear of people, obstructions, holes and drop-offs, is level and is capable of supporting wheel loads.
2. Verify that the Chassis Key Switch is turned to ON and the Chassis Emergency Stop Switch is ON, (pull button out).
3. After mounting the platform, lower the bar across entrance.
4. Check clearances above, below and to the sides of the machine.
5. Pull the Controller Emergency Stop switch up to the ON position.
6. Select DRIVE mode.
7. While depressing the Interlock Switch, slowly push or pull the Control Lever to FORWARD or REVERSE position to travel in the desired direction. The farther you push or pull the Control Lever from center the faster the machine will travel.

STEERING

NOTE: Steering is not self-centering. Wheels must be returned to straight ahead position by operating the Steering Switch.

1. Select DRIVE mode.
2. While depressing the Interlock Switch, push the Steering Switch to RIGHT or LEFT to turn the wheels in the desired direction. Observe the tires while maneuvering the machine to ensure proper direction.

ELEVATING PLATFORM

1. Select LIFT mode.
2. While depressing the Interlock Switch, push Control Lever forward to UP, the farther you push the Control Lever the faster the Platform will elevate.
3. If the machine is not level the Tilt Alarm will sound and the machine will not lift or drive. If the Tilt alarm sounds the platform must be lowered and the machine moved to a level location before attempting to re-elevate the Platform.

TRAVEL WITH PLATFORM ELEVATED

NOTE: The machine will travel at reduced speed when the platform is elevated.

1. Check that the route is clear of persons, obstructions, holes and drop-offs, is level and capable of supporting the wheel loads.
2. Check clearances above, below and to the sides of the platform.
3. Select DRIVE mode.
4. While depressing the Interlock Switch, push Control Lever to FORWARD or REVERSE for desired direction of travel.
5. If the machine is not level the Tilt Alarm will sound and the machine will not lift or drive. If the Tilt alarm sounds the platform must be lowered and the machine moved to a level location before attempting to re-elevate the Platform.

LOWERING PLATFORM

1. Select LIFT mode.
2. While depressing the Interlock Switch, pull back on the Control Lever.

EMERGENCY LOWERING

⚠ WARNING ⚠

If the platform should fail to lower, NEVER climb down the elevating assembly.

Stand clear of the elevating assembly while operating the Emergency Lowering Valve Knob.

Ask a person on the ground to open the Emergency Lowering Valve to lower the platform. The Emergency Lowering Valve is located at the front of the chassis.

1. Open the Emergency Lowering Valve by pulling the knob out.
2. To close, release the knob.

NOTE: The platform will not elevate if the Emergency Lowering Valve is open.

Figure 4: Emergency Lowering Valve

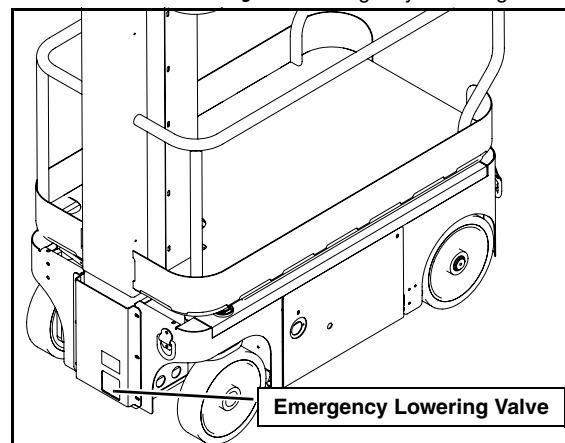

PARKING BRAKE RELEASE

Perform the following procedure only when the machine will not operate under its own power and it is necessary to move the machine, or when winching onto a trailer to transport.

1. Remove the spring compression nut so the spring is loose and the brake bars are away from the tires.
2. The machine will now roll when pushed or pulled.

After moving the machine and before normal operation:

1. Replace the spring compression nut and tighten until the spring measures 22,2-22,9 cm (8¾"-9") in length, verify that the brake bars have fully engaged the tires before the machine is operated.

Figure 5: Parking Brake Release

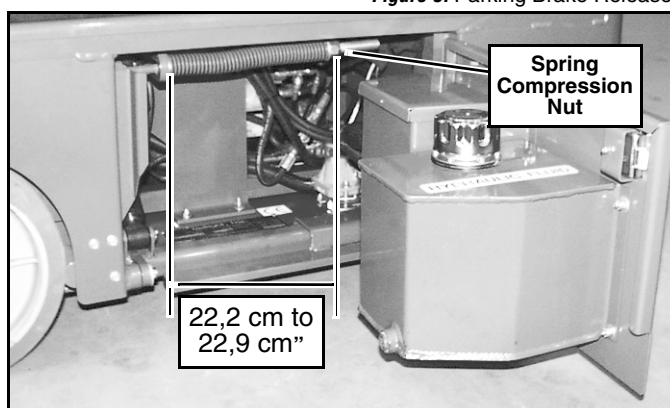

⚠ WARNING ⚠

Never tow faster than 0,3 m/sec. (1 ft./sec.).

Never operate the machine with the parking brakes released. Serious injury or damage could result.

AFTER USE EACH DAY

1. Ensure that the platform is fully lowered.
2. Park the machine on a firm level surface, preferably under cover, secure against vandals, children and unauthorized operation.
3. Turn the Chassis Key Switch to OFF and remove the key to prevent unauthorized operation.

TRANSPORTING THE MACHINE

BY CRANE

Secure the straps to chassis lifting/tie down points only.

BY FORKLIFT

⚠ DANGER ⚠

Forklifting is for transport only.

See specifications for weight of machine and be certain that forklift is of adequate capacity to lift the machine.

Forklift from the side by lifting under the Chassis.

BY TRUCK

1. Maneuver the machine into transport position and chock wheels.
2. Secure the machine to the transport vehicle with chains or straps of adequate load capacity attached to the chassis lifting/tie down points.

CAUTION

Overtightening of the chains or straps attached to the Tie Down lugs may result in damage to the machine

Figure 6: Transporting the Machine

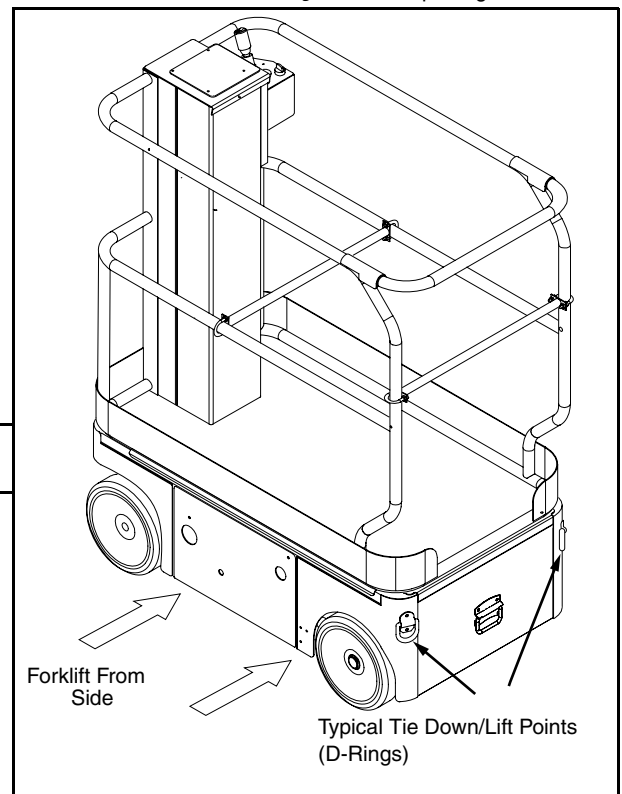

HOURLY METER

To access the hour meter function perform the following steps.

1. Climb into the basket (with the machine powered up)
2. Push the platform emergency stop button.
3. Hold down the following buttons, Horn and Lift.
4. While holding the buttons twist the emergency stop button to return power to the machine.
5. "hr" will now be displayed on the readout, Pressing the right turn button will scroll through the accumulated hours two digits at a time. For example, if pressing the right turn button once displays "20", pressing it a 2nd time displays "58", and pressing it a 3rd time displays "hr", the elapsed time of operation is 2058 hours.

MAINTENANCE

⚠ WARNING ⚠

Never perform service while the platform is elevated without first blocking the elevating assembly.
DO NOT stand in the elevating assembly area while deploying or storing the brace.

BLOCKING THE ELEVATING ASSEMBLY

INSTALLATION

1. Park the machine on firm level ground.
2. Verify that both Emergency Stop Switches are ON.
3. Turn and hold the Chassis Key Switch to CHASSIS.
4. Position the Chassis Lift Switch to UP and elevate the platform approximately 1,2 m (4 ft.).
5. Place a solid wood block, 51mm x 100mm x 45cm (2"x 4"x18") between the second mast section and Chassis just behind the mast assembly.
6. Push the Chassis Lift Switch to the DOWN position and gradually lower the platform until the second mast section is supported by the block.

Figure 7: Supporting the Elevating Assembly

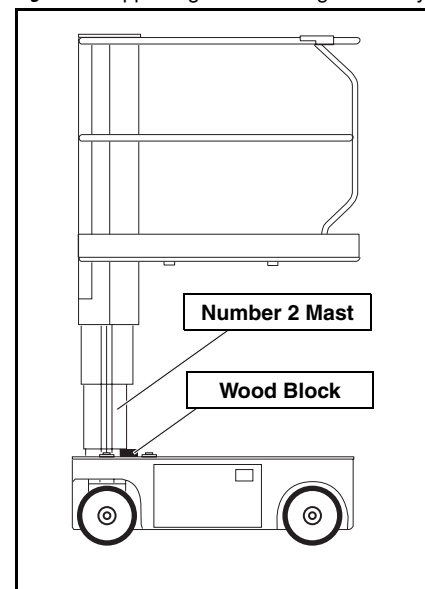

REMOVAL

1. Push the Chassis Lift Switch to the UP position and gradually raise platform until the wood block can be removed.
2. Remove the block.
3. Push the Chassis Lift Switch to the DOWN position and completely lower the platform.

HYDRAULIC FLUID

The hydraulic fluid reservoir is located in the chassis door.

NOTE: Never add fluid if the platform is elevated.

CHECK HYDRAULIC FLUID

1. Make sure that the platform is fully lowered.
2. Open the chassis door.
3. Remove the filler cap from the hydraulic fluid reservoir.
4. Check the fluid level on the dipstick on the filler cap.
5. Add the appropriate fluid to bring the level to the FULL mark. See "Specifications" on page 14

Figure 8: Hydraulic Fluid Reservoir and Dipstick



BATTERY MAINTENANCE

Figure 9: Access to Batteries

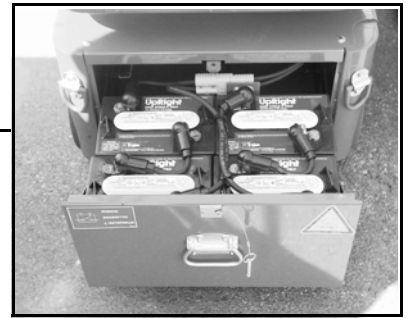

WARNING

Hazard of explosive gas mixture. Keep sparks, flame, and smoking material away from batteries.

Always wear safety glasses when working near batteries.

Battery fluid is highly corrosive. Thoroughly rinse away any spilled fluid with clean water.

Always replace batteries with UpRight batteries or manufacturer approved replacements weighing 26,3 kg (58 lbs.) each.

- Check the battery fluid level daily, especially if the machine is being used in a warm, dry climate.
- Keep the terminals and tops of the batteries clean.
- Refer to the Service Manual to extend battery life and for complete service instructions.

BATTERY CHARGING

Figure 10: Battery Charge Indicator

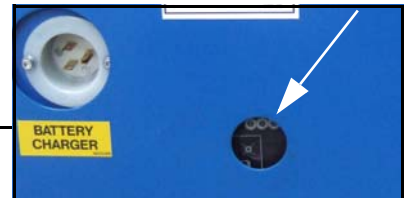

WARNING

Charge the batteries in a well ventilated area.

Do not charge the batteries when the machine is near a source of sparks or flames.

Permanent damage to the batteries will result if the batteries are not immediately recharged after discharging.

Never leave the battery charger operating for more than two days.

Never disconnect the cables from the batteries when the charger is operating.

Keep the charger dry.

1. Check the battery fluid level. If the battery fluid level is lower than 10 mm ($\frac{3}{8}$ in.) above the plates add distilled water only.
2. Connect an extension cord (1,5 mm² [12 gauge] minimum conductor diameter; 15 m (50 ft.) maximum length) to the charger plug located at the left side of the chassis.
3. The charger turns on automatically after a short delay. Look through the charge indicator cutout to check the state of charge.
 - 0 - 50% charge:
 - First Light -BLINKING-
 - Second and Third Light -OFF-
 - 50% - 75% Charge:
 - First Light -ON-
 - Second Light -BLINKING-
 - Third Light -OFF-
 - 75% - 100% Charge:
 - First and Second Light -ON-
 - Third Light - BLINKING-
 - Charge Complete
 - All Lights -ON-
 - The charger automatically shuts down to low current after charging is complete and all lights turn ON.
 - The charger continues at low current (equalizing charge) for 3-4 hours, then charging current shuts off completely.
4. Lights remain ON until the AC power supply is disconnected.

NOTE: The battery charger circuit must be used with a GFI (Ground Fault Interrupt) outlet.

NOTE: DO NOT operate the machine while the charger is plugged in.

INSPECTION AND MAINTENANCE SCHEDULE

The Complete Inspection consists of periodic visual and operational checks, along with periodic minor adjustments that assure proper performance. Daily inspection will prevent abnormal wear and prolong the life of all systems. The inspection and maintenance schedule should be performed at the specified intervals. Inspection and maintenance shall be performed by personnel who are trained and familiar with mechanical and electrical procedures.

! WARNING !

*Before performing preventative maintenance, familiarize yourself with the operation of the machine.
Always block the elevating assembly whenever it is necessary to perform maintenance while the platform is elevated.*

The daily preventative maintenance checklist has been designed for machine service and maintenance. Please photocopy the Daily Preventative Maintenance Checklist and use the checklist when inspecting the machine.

DAILY PREVENTATIVE MAINTENANCE CHECKLIST

MAINTENANCE TABLE KEY

Y = Yes/Acceptable

N = No/Not Acceptable

R = Repaired/Acceptable

PREVENTATIVE MAINTENANCE REPORT

Date: _____

Owner: _____

Model No: _____

Serial No: _____

Serviced By: _____

COMPONENT	INSPECTION OR SERVICES	Y	N	R
Battery	Check electrolyte level.			
	Check battery cable condition.			
Chassis	Check hoses for pinch or rubbing points.			
	Check welds for cracks.			
Control Cable	Check the exterior of the cable for pinching, binding or wear.			
Controller	Check switch operation.			
Drive Motors	Check for operation and leaks.			
Elevating Assembly	Inspect for structural cracks.			
Emergency Hydraulic System	Operate the emergency lowering valve and check for serviceability.			

COMPONENT	INSPECTION OR SERVICES	Y	N	R
Entire Unit	Check for and repair collision damage.			
Hydraulic Fluid	Check fluid level.			
Hydraulic Pump	Check for hose fitting leaks.			
Hydraulic System	Check for leaks.			
Labels	Check for peeling, missing, or unreadable labels & replace.			
Platform Deck and Rails	Check welds for cracks.			
Platform Deck and Rails	Check condition of deck.			
Tires	Check for damage.			

SPECIFICATIONS

ITEM	TM12
Platform Size	73,7 cm x 1,04 m (29 in. x 41 in.)
Maximum Platform Capacity	227 kg (500 lbs.)
Maximum Number of Occupants	2 People indoors/1 person outdoors
Height	
Working Height	5,83 m (19 ft.)
Maximum Platform Height	3,83 m (12.5 ft.)
Minimum Platform Height	48,3 cm (19 in.)
Dimensions	
Weight	776 kg (1710 lbs.)
Overall Width	76 cm (30 in.)
Overall Height	165 cm (65 in.)
Overall Length	1,36 m (53.5 in.)
Drive Speed	
Platform Lowered	3,65 km/h (2.27 mph)
Platform Raised	0,87 km/h (0.54 mph)
Energy Source	24V battery pack Four 220 ampere hour, 6 Volt batteries, min. wt. 26,3 kg (58 lbs.) each 4 HP DC electric motor
System Voltage	24 VDC
Battery Charger	20 AMP, 220 V AC 50Hz
Battery Duty Cycle	25% for 8 Hours
Hydraulic Reservoir Capacity	7,2 L (1.9 gal)
Maximum Hydraulic System Pressure	165 bar (2400 psi)
Hydraulic Fluid	
Normal above 32° F [0° C]	ISO #46
Low Temp. below 32° F [0° C]	ISO #32
below 0° F [-17° C]	ISO #15
Lift System	One Single Stage Lift Cylinder
Drive Control	Proportional
Control System	Proportional Control Handle with Interlock, Selector Switch, Red Mushroom Emergency Stop Switches
Horizontal Drive	Dual Front Wheel
Tires	30,5 cm (12 in.) diameter solid rubber, Non-marking
Parking Brakes	Dual, Spring Applied, Hydraulic Release
Turning Radius	37 cm (14.5 in.) Inside
Maximum Gradeability	14° (25%)
Wheel Base	97,8 cm (38.5 in.)
Guardrails	1,10 m (43 in.)
Toeboard	152 mm (6 in.)
Noise Level	

*Specifications are subject to change without notice. Hot weather or heavy use may affect performance.

Refer to the Service Manual for complete parts and service information.

This machine meets or exceeds all applicable CE and GS machinery directive requirements.

NOTES:

SERVICE AND REPAIR

This section contains instructions for the maintenance of the Work Platform. Refer to the General Information section for information relevant to all UpRight Powered Access work platforms. Referring to the Operator Manual will aid in understanding the operation and function of the various components and systems of the work platform, and help in diagnosing and repair of the machine.

! WARNING !

Be sure to read, understand and follow all information in the Operation Section of this manual before attempting to operate or perform service on any Work Platform.

! DANGER !

*Never perform service on the work platform in the elevating assembly area while platform is elevated without first blocking the elevating assembly.
DO NOT stand in elevating assembly area while deploying or storing brace.*

TABLE OF CONTENTS

3-1 Supporting Elevating Assembly	3-3
Installation	3-3
Removal	3-3
3-2 Preventative Maintenance	3-4
3-3 Preventative Maintenance Check List	3-5
3-4 Parts Location	3-6
3-5 General Lubrication	3-7
3-6 Batteries	3-8
Battery Replacement	3-8
Battery Maintenance	3-8
3-7 Hydraulics	3-9
Hydraulic Oil Tank And Filter	3-9
Hydraulic Pump	3-10
Cylinder valve Assembly	3-11
Main Hydraulic Manifold	3-12
Setting Hydraulic Manifold Pressures	3-13
3-8 Cylinders	3-15
Depression Cylinder	3-15
Brake Cylinder	3-16
Steering Cylinder	3-17
Lift Cylinder	3-18
3-9 Drive Motors	3-19
Removal	3-19
Installation	3-19

3-10 Elevating Assembly	3-20
Lift Chain Lubrication	3-21
Elevating Assembly Wear Inspection	3-21
Chain Tension Inspection	3-22
Chain Elongation Inspection	3-22
Removal of Elevating Assembly	3-23
Installation of Elevating Assembly	3-23
3-11 Tilt Sensor	3-24
3-12 Controls	3-25
Platform Controls	3-25
Chassis Controls	3-26

LIST OF FIGURES

Figure 3-1: Supporting Elevating Assembly	3-3
Figure 3-2: Parts Location	3-6
Figure 3-3: Lubrication Points	3-7
Figure 3-4: Battery Cables	3-8
Figure 3-5: Hydraulic Oil Tank and Filter	3-9
Figure 3-6: Hydraulic Pump	3-10
Figure 3-7: Cylinder Valve	3-11
Figure 3-8: Hydraulic Manifold, Exploded View	3-12
Figure 3-9: Hydraulic Manifold	3-13
Figure 3-10: Depression Cylinder Remove & Replace	3-15
Figure 3-11: Brake Cylinder, Remove & Replace	3-16
Figure 3-12: Steering Cylinder Remove & Replace	3-17
Figure 3-13: Brake and Steering Cylinder Seal Kit	3-17
Figure 3-14: Lift Cylinder Seal Kit	3-18
Figure 3-15: Drive Motor Assembly	3-19
Figure 3-16: Elevating Assembly	3-20
Figure 3-17: Chain Elongation Inspection	3-22
Figure 3-18: Tilt Sensor	3-24
Figure 3-19: Upper Controls	3-25
Figure 3-20: Chassis Controls	3-26

3-1 SUPPORTING ELEVATING ASSEMBLY

⚠ WARNING ⚠

Never perform service on the work platform in the elevating assembly area while platform is elevated without first blocking the elevating assembly.

DO NOT stand in elevating assembly area while deploying or storing brace.

INSTALLATION

1. Park the Work Platform on firm level ground.
2. Verify Platform Emergency Stop Switch is **ON**.
3. Verify Platform Key Switch is **ON**.
4. Press the Enable button and push Chassis Lift/Lower toggle Switch to **UP** to elevate Platform approximately 1.2m (**4 feet**).
5. Place a wood block, 5cm x 10cm x 46cm (**2 in. x 4 in. x 18 in.**) long between the #2 Mast and Chassis just behind the Mast Assembly.
6. Press the Enable button and push Chassis Lift/Lower toggle Switch to **DOWN** position and gradually lower Platform until the #2 Mast is supported by the block.

REMOVAL

1. Press the Enable button and push Chassis Lift/Lower toggle Switch to **UP** to gradually raise Platform until wood block can be removed.
2. Remove block.
3. Press the Enable button and push Chassis Lift/Lower toggle Switch to **DOWN** position and completely lower Platform

Figure 3-1: Supporting Elevating Assembly

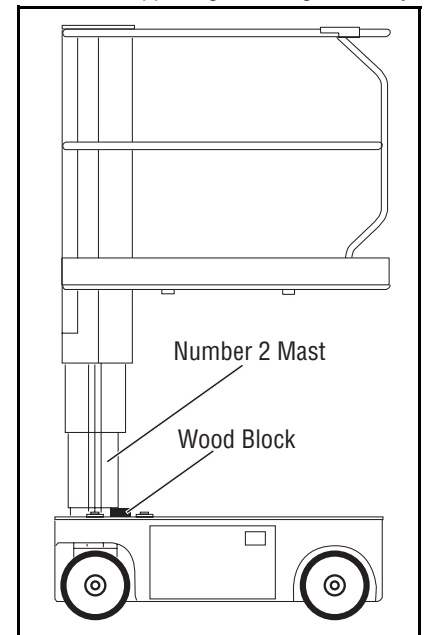

3-2 PREVENTATIVE MAINTENANCE

The complete inspection consists of periodic visual and operational checks, along with periodic minor adjustments to assure proper performance. Daily inspection will prevent abnormal wear and prolong the life of all systems. The inspection and maintenance schedule is to be performed at regular intervals. Inspection and maintenance shall be performed by personnel who are trained and familiar with mechanical and electrical procedures.

! WARNING !

Before performing preventative maintenance, familiarize yourself with the operation of the machine.

Always block the elevating assembly whenever it is necessary to enter the scissor assembly to perform maintenance while the platform is elevated.

The preventative maintenance table has been designed for machine service and maintenance repair. Please photocopy the following page and use the table as a checklist when inspecting the machine for service.

3-3 PREVENTATIVE MAINTENANCE CHECK LIST

PREVENTATIVE MAINTENANCE KEY

Interval

- Daily=each shift or every day
- 50h/30d=every 50 hours or 30 days
- 250h/6m=every 250 hours or 6 months
- 1000h/2y=every 1000 hours or 2 years
- Y=Yes/Acceptable
- N=No/Not Acceptable
- R=Repaired/Acceptable

PREVENTATIVE MAINTENANCE REPORT

Date: _____

Owner: _____

Model No: _____

Serial No: _____

Serviced By: _____

Service Interval: _____

COMPONENT	INSPECTION OR SERVICES	INTERVAL	Y	N	R
Battery System	Check electrolyte level	Daily			
	Check battery cable condition	Daily			
	Charge batteries	Daily			
	Check charger condition & operation	Daily			
	Check specific gravity	6m			
	Clean exterior	6m			
	Clean terminals	6m			
Hydraulic Oil*	Check oil level	Daily			
	Change Filter	6m			
	Drain and replace oil	2y			
Hydraulic System	Check for leaks	Daily			
	Check hose connections	30d			
	Check hoses for exterior wear	30d			
Drive Motors	Check for operation and leaks	Daily			
Emergency Down	Check procedure for Emergency Down	Daily			
Hydraulic Pump	Check for fitting leaks	Daily			
	Wipe clean	30d			
	Check for leaks at mating surfaces	30d			
	Check mounting bolts for proper torque	6m			
Controller	Check condition & operation	Daily			
Platform Deck & Rails	Check fasteners for proper torque	Daily			
	Check welds for cracks	Daily			
	Check condition of deck	Daily			
	Check entry way closure	Daily			

COMPONENT	INSPECTION OR SERVICES	INTERVAL	Y	N	R
Elevating Assembly	Inspect for external damage, dents, loose rivets or cracks	Daily			
	Check chains and sheaves for wear	6m			
	Lubricate lift chains	6m			
	Check chain tension	1yr			
	Remove and inspect chains	5yr			
Chassis	Check cables for pinch or rubbing points	Daily			
	Check welds for cracks	Daily			
	Check component mounting for proper torque	6m			
Lift Cylinder	Check for leaks	Daily			
	Check for proper torque	6m			
Entire Unit	Perform pre-operation inspection	Daily			
	Check for and repair collision damage	Daily			
	Lubricate	30d			
	Check fasteners for proper torque	6m			
Labels	Check for corrosion; remove and repaint	6m			
	Check for peeling, missing, or unreadable labels & replace	Daily			
Wheels	Check for loose components	Daily			
Steering System	Oil pivot pins	30d			
	Oil king pins	30d			
	Check steering cylinder for leaks	30d			
	Check hardware & fittings for proper torque	6m			

* NOTE: Use ISO #46 during summer and ISO #32 during winter.

3-4 PARTS LOCATION

Figure 3-2: Parts Location

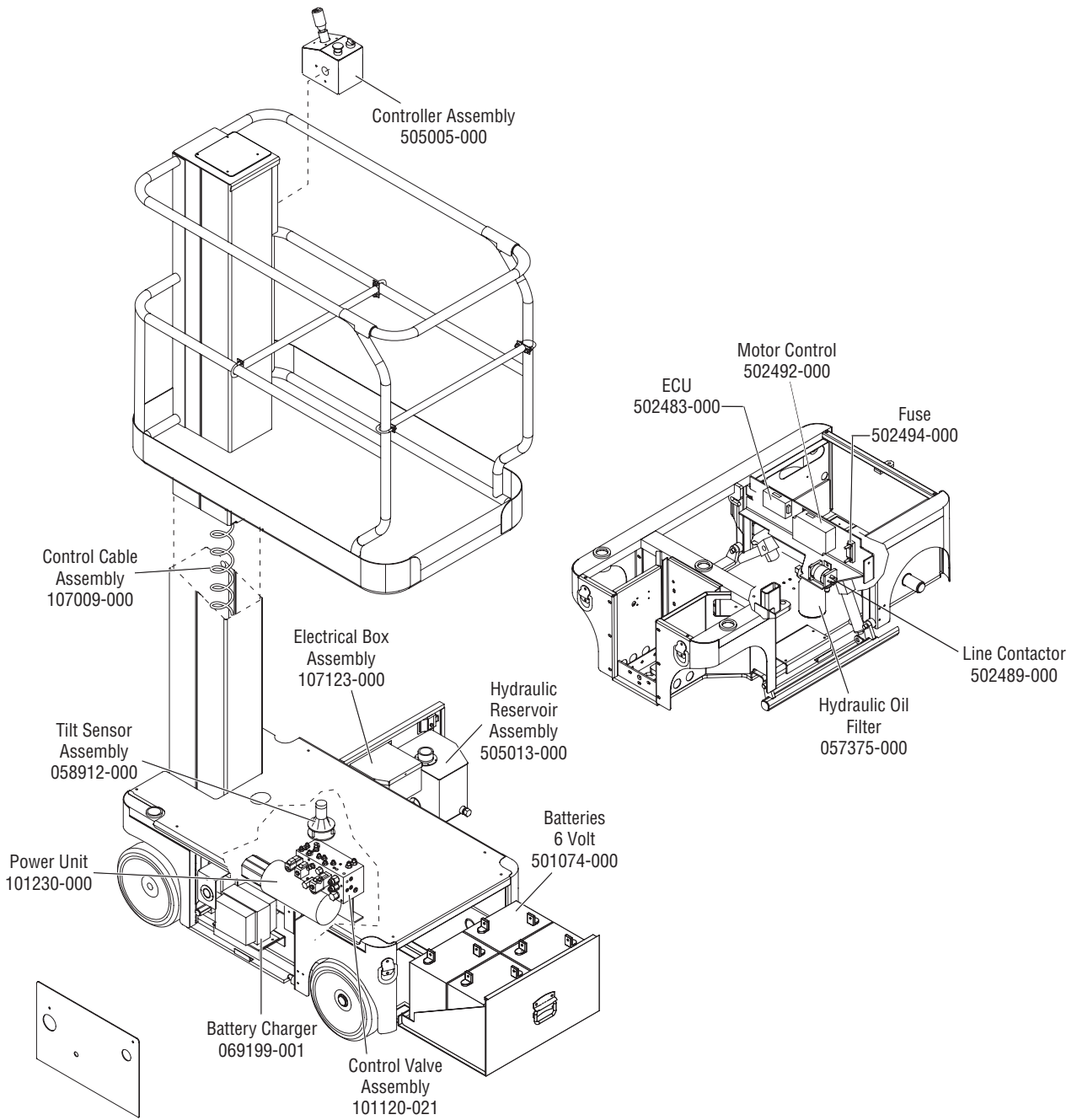

3-5 GENERAL LUBRICATION

- Apply grease to each grease fitting.
- Apply one or two drops of motor oil to each bearing.

Figure 3-3: Lubrication Points

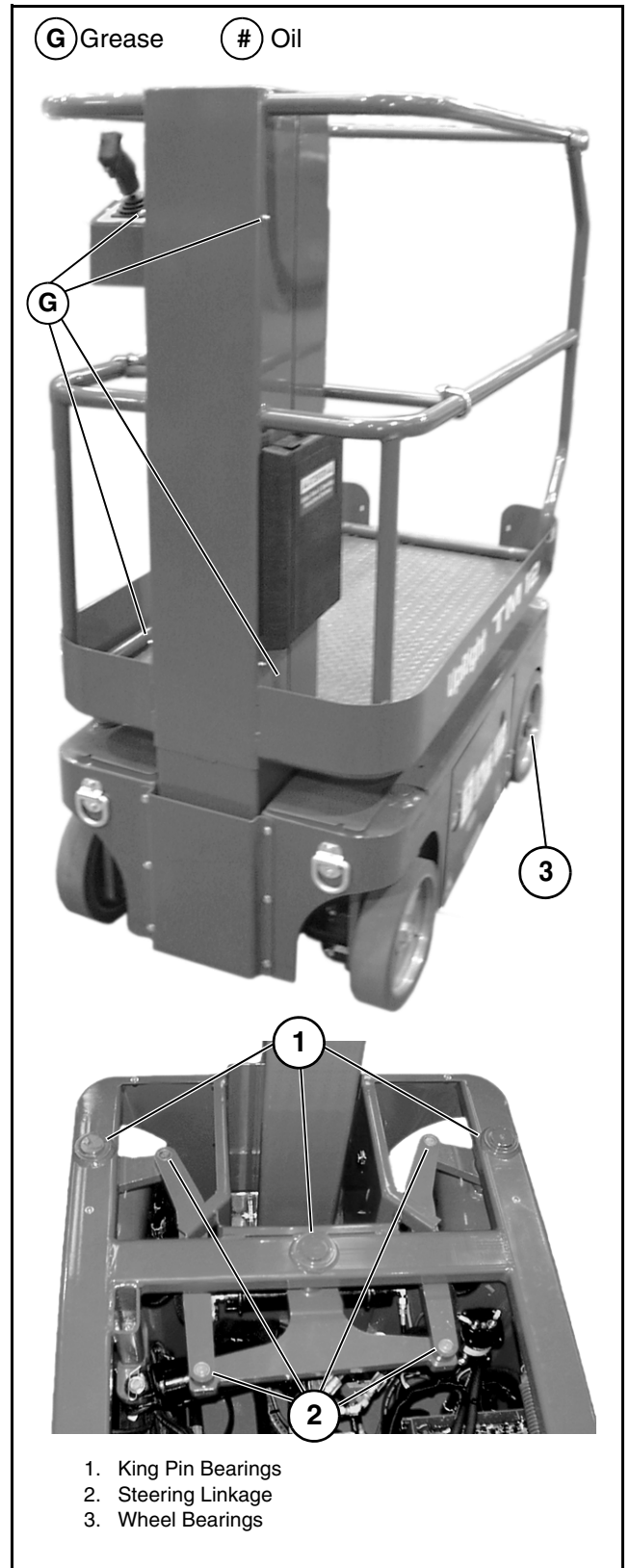

3-6 BATTERIES

Electrical Energy for the motor is supplied by four 6 volt batteries wired in series for 24 volts DC. Proper care and maintenance of the batteries and motor will ensure maximum performance from the work platform.

CAUTION

If battery water level is not maintained, batteries will not fully charge, creating a low discharge rate.

WARNING

Hazard of explosive gas mixture. Keep sparks, flame and smoking materials away from batteries. Always wear safety glasses when working with batteries. Battery fluid is highly corrosive. Thoroughly rinse away any spilled fluid with clean water. Always replace batteries with UpRight batteries or manufacturer approved replacements. Before disconnecting the battery negative (-) lead, make sure all switches are OFF. If ON, a spark will occur at the ground terminal which could cause an explosion if hydrogen gas or fuel vapors are present.

BATTERY REPLACEMENT

The batteries are located in a slide-out tray in the rear of the machine. There are four 6 volt batteries wired in series for 24 volts DC. Battery cables must be installed as shown in the Battery Cable Installation Diagram.

BATTERY MAINTENANCE

Refer to *Section 1: General Information* for complete battery maintenance instructions.

Refer to the *Operation Manual* included in this Service Manual for specific maintenance and charging instructions.

Figure 3-4: Battery Cables

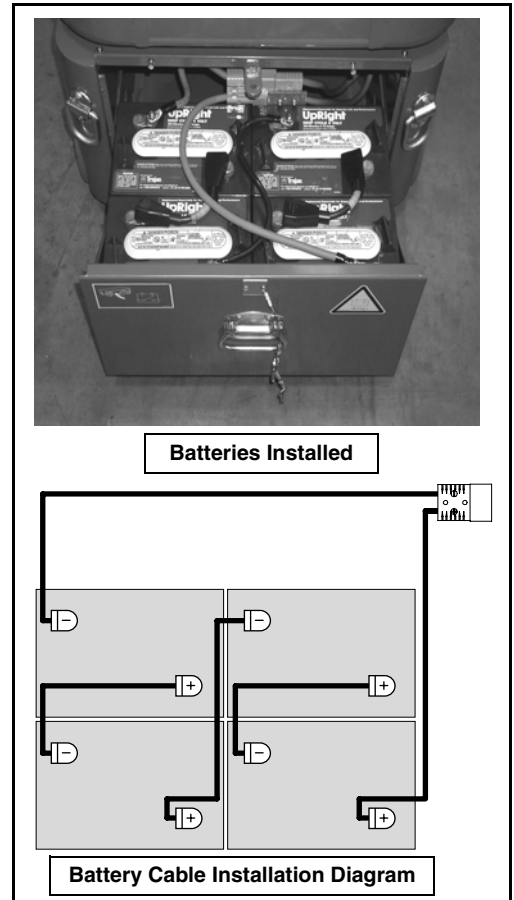

3-7 HYDRAULICS

HYDRAULIC OIL TANK AND FILTER

FLUID LEVEL

With Platform fully lowered, oil should be visible on the dipstick, if not, fill the tank until oil registers on the dipstick. **DO NOT** fill above the lower line on the dipstick or when the Platform is elevated.

OIL AND FILTER REPLACEMENT

1. Operate the work platform for 10-15 minutes to bring the hydraulic oil up to normal operating temperature.
2. Provide a suitable container to catch the drained oil. Hydraulic tank has a 7,2 liter (**1.9 US gal.**) capacity.
3. Open module door.
4. Remove the magnetic drain plug and allow all oil to drain.
5. Check the magnetic plug for metal fragments.
6. Clean and re-install the drain plug.
7. Un-thread the suction screen from the tank.
8. Wash the suction screen in cleaning solvent and then blow out with clean compressed air.
9. Apply a thin film of clean hydraulic oil (ISO #46) to the threads and re-install the suction screen.
10. Un-thread the filter from the filter head.
11. Apply a thin film of clean hydraulic oil (ISO #46) to the gasket of the replacement filter.
12. Thread the replacement filter onto the filter head until the gasket makes contact, then rotate the filter $\frac{3}{4}$ of a turn further.
13. Fill the hydraulic reservoir with hydraulic oil until the oil comes up just past the end of the dipstick. Hydraulic tank has a 7,2 liter (**1.9 US gallon**) capacity.

Figure 3-5: Hydraulic Oil Tank and Filter

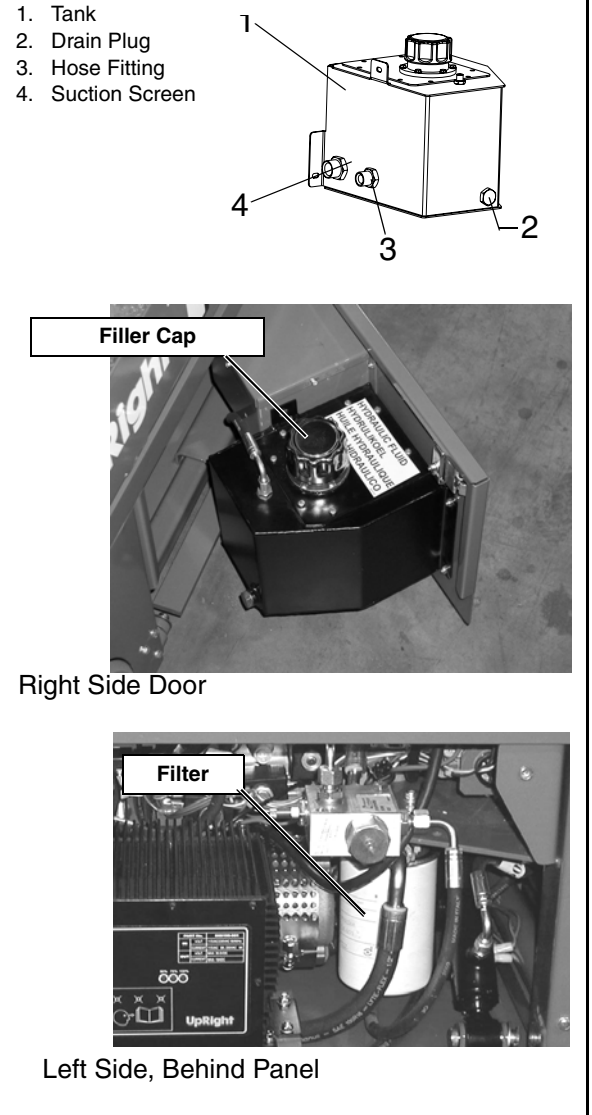

CAUTION

The hydraulic oil may be of sufficient temperature to cause burns. Wear safety gloves and safety glasses when handling hot oil.

HYDRAULIC PUMP

The Hydraulic Pump is located in the Power Module, and is mounted on the rear of the motor.

REMOVAL

NOTE: If the hydraulic tank has not been drained, suitable means for plugging the hoses should be provided to prevent excessive fluid loss.

1. Mark, disconnect and plug the hose assemblies.
2. Loosen the capscrews and remove the pump assembly from the motor.

INSTALLATION

1. Lubricate the pump shaft with general purpose grease and attach the pump to the motor with the capscrews.
2. Using a crisscross pattern, torque each cap-screw a little at a time until all capscrews are torqued to 27N-m (**20 ft-lbs**).
3. Unplug and reconnect the hydraulic hoses.
4. Check the oil level in the hydraulic tank before operating the work platform.

CYLINDER VALVE ASSEMBLY

Figure 3-6: Hydraulic Pump

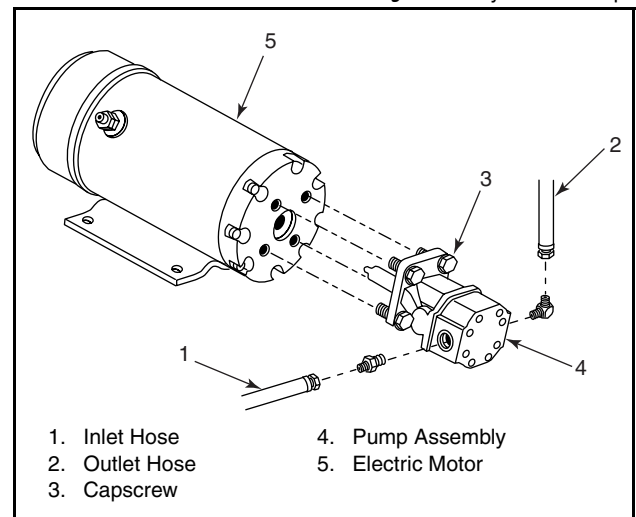
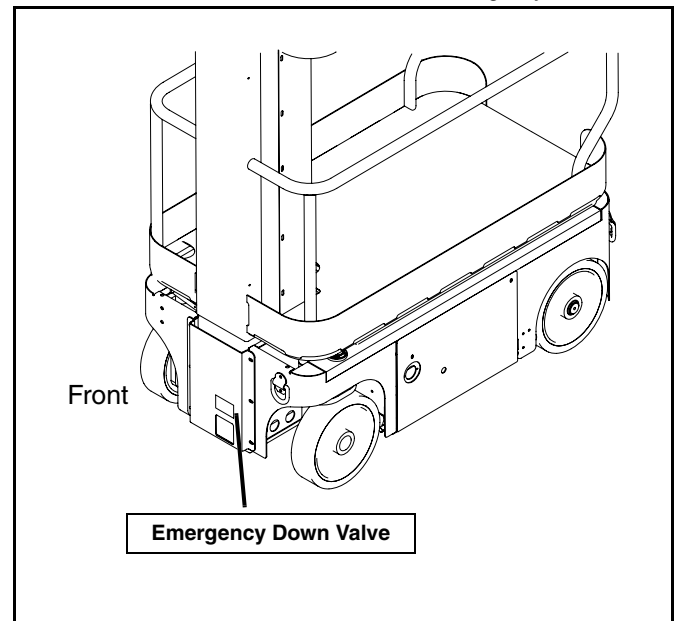

Figure 3-7: Emergency Down Valve

EMERGENCY DOWN VALVE

The Emergency Down Valve located at the front of the machine. The valve is a 24 Volt DC solenoid mounted on the base of the cylinder.

Pull to activate



MAIN HYDRAULIC MANIFOLD

Though it is not necessary to remove the manifold to perform all maintenance procedures, a determination should be made prior to beginning as to whether or not the manifold should be removed before maintenance procedures begin.

Figure 3-8: Hydraulic Manifold, Exploded View

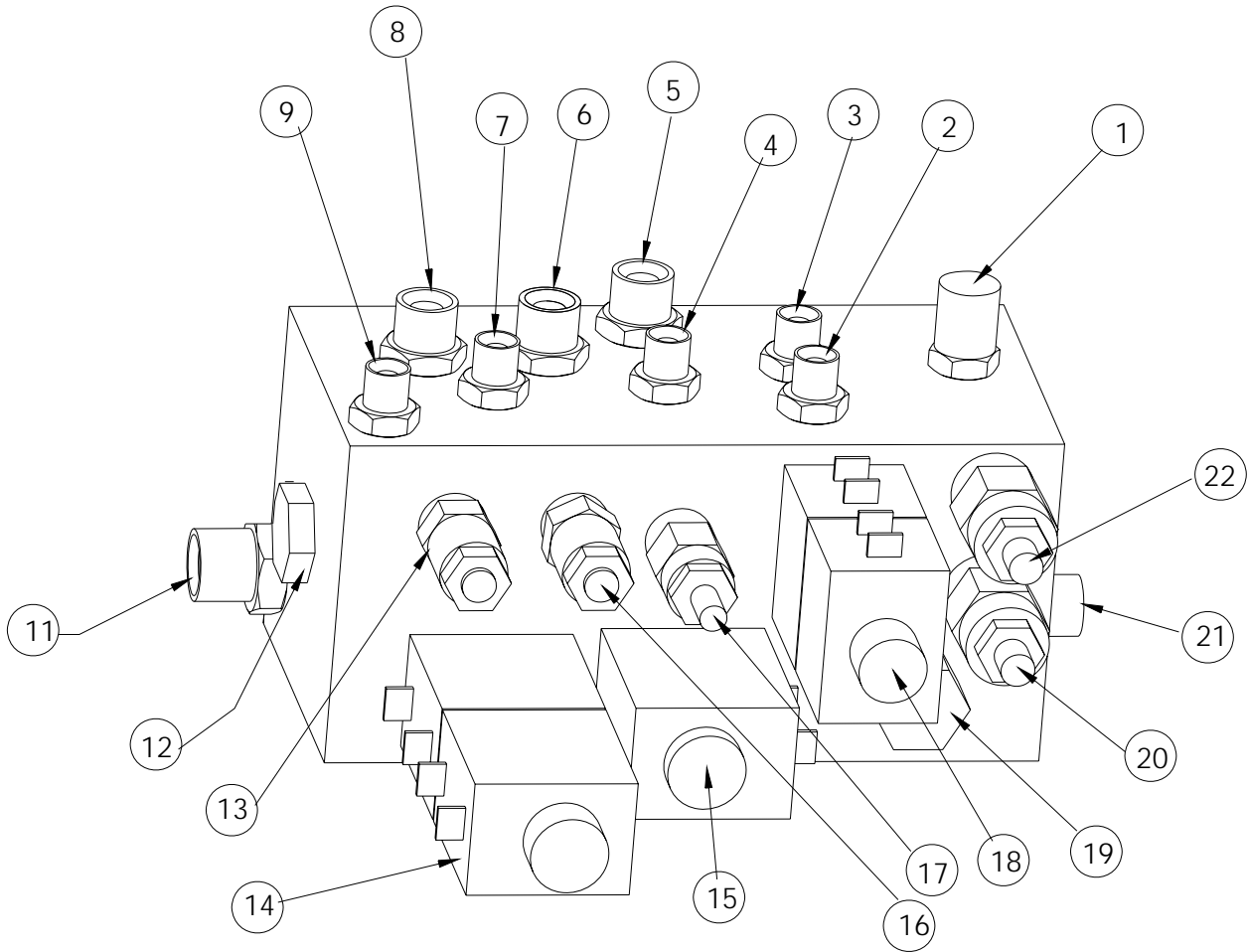

- | | |
|---|-------------------------------------|
| 1. TEST PORT (1/4") | 12. CHECK VALVE (POTHOLE) |
| 2. FITTING (1/4" - 1/4" MALE/MALE) | 13. CROSS LINE RELIEF VALVE (DRIVE) |
| 3. FITTING (1/4" - 1/4" MALE/MALE) | 14. SOLENOID VALVE (DRIVE)) |
| 4. FITTING (1/4" - 1/4" MALE/MALE) | 15. SOLENOID VALVE (DRIVE/LIFT) |
| 5. FITTING (3/8" - 3/8" MALE/MALE) | 16. CROSS LINE RELIEF VALVE (DRIVE) |
| 6. FITTING (3/8" - 3/8" MALE/MALE) | 17. PRESSURE RELIEF (MAIN LIFT) |
| 7. FITTING (1/4" - 1/4" MALE/MALE WITH 1mm OROFICE) | 18. SOLENOID VALVE (STEERING) |
| 8. FITTING (3/8" - 3/8" MALE/MALE) | 19. FLOW RESTRICTOR (STEERING) |
| 9. FITTING (1/4" - 1/4" MALE/MALE) | 20. RELIEF VALVE (STEERING) |
| 10. - | 21. FITTING (3/8" - 3/8" MALE/MALE) |
| 11. FITTING (1/2" - 1/2" MALE/MALE) | 22. RELIEF VALVE (MAIN) |

SETTING HYDRAULIC MANIFOLD PRESSURES

⚠ WARNING ⚠

The hydraulic oil may be of sufficient temperature to cause burns. Wear safety gloves and safety glasses when handling hot oil.

The oil in the hydraulic system is under very high pressure which can easily cause severe cuts. **Obtain medical assistance immediately if cut by hydraulic oil.**

NOTE: Check the hydraulic pressures whenever the pump, manifold or relief valves have been serviced or replaced

MAIN RELIEF VALVE

1. Operate the hydraulic system 10 to 15 minutes to warm the oil.
2. Remove the cap or loosen the locknut on the Main Relief Valve.
3. Install a 0-207 bar (**0-3000 psi**) pressure gauge to the gauge port.
4. Turn the Chassis Keyswitch to CHASSIS and elevate the machine fully.
5. While holding the Chassis Lift Switch to the UP position, adjust the Main Relief Valve until the pressure gauge reads 165 bar (**2400 psi**).
6. Release the Chassis Lift Switch.
7. Replace the cap, or tighten the locknut on the Lift Relief Valve, and torque to 8N-m (**6 ft-lbs**).
8. Lower the platform.

Figure 3-9: Hydraulic Manifold

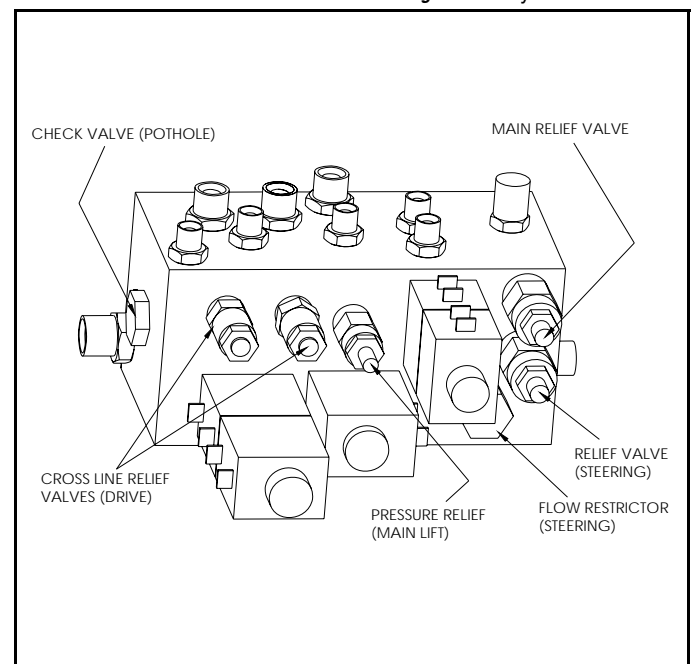

COUNTERBALANCE VALVES

1. Operate the work platform for 10-15 minutes to bring the hydraulic oil up to normal operating temperature.
2. Remove the gauge port cap and install the pressure gauge assembly.
3. Lift work platform and block front wheels off ground.
4. Loosen the locknuts on Counterbalance Valves.
5. With the machine fully powered up depress the **DRIVE** button on the upper control box, depress the interlock lever and slowly pull the control lever to **REVERSE** to drive the wheels.
6. Adjust the Forward Counterbalance Valve by turning the adjustment screw until the pressure gauge indicates 83 bar (**1200 psi**).
7. Slowly push the Control Lever to **FORWARD** to drive the wheels.
8. Adjust the Reverse Counterbalance Valve by turning the adjustment screw until the pressure gauge indicates 83 bar (**1200 psi**).
9. Check the settings by slowly moving the Control Lever **FORWARD**, then **REVERSE**, checking the gauge to ensure pressures are properly set. Re-adjust as needed.
10. Tighten locknuts on valves to 8N-m (**6 ft-lbs**). Remove blocks and lower work platform to ground.
11. Reconnect the red Control Cable wire to terminal #9.
12. Remove the gauge from the gauge port and re-install cap.
13. Check for proper operation of the drive system and brake.

STEERING RELIEF VALVES

1. Operate the work platform for 10-15 minutes to bring the hydraulic oil up to normal operating temperature.
2. Install gauge in the gauge port.
3. Loosen locknut or remove cover on the Steering Relief Valve and turn adjusting screw counter-clockwise two full turns.
4. While one person holds the Steering Switch to steer right or left, slowly turn the Steering Relief Valve adjusting screw clockwise to increase the pressure until the gauge reads 69 bar (**1000 psi**).
5. Tighten locknut or replace Steering Relief Valve cover and torque to 8N-m (**6 ft-lbs**).
6. Remove gauge and replace cap.

3-8 CYLINDERS

DEPRESSION CYLINDER

REMOVAL

1. Mark and disconnect the hose assemblies from the cylinder fittings and immediately cap the openings to prevent foreign material from entering.
2. Place a support under the depression guard.
3. Remove the cotter pins from the pivot pins.
4. Remove the pivot pins while supporting the cylinder.
5. Remove the cylinder.

REPAIR

Refer to Cylinder Repair in Section 1 - General Information.

INSTALLATION

Installation is reverse of removal.

Figure 3-10: Depression Cylinder Remove & Replace

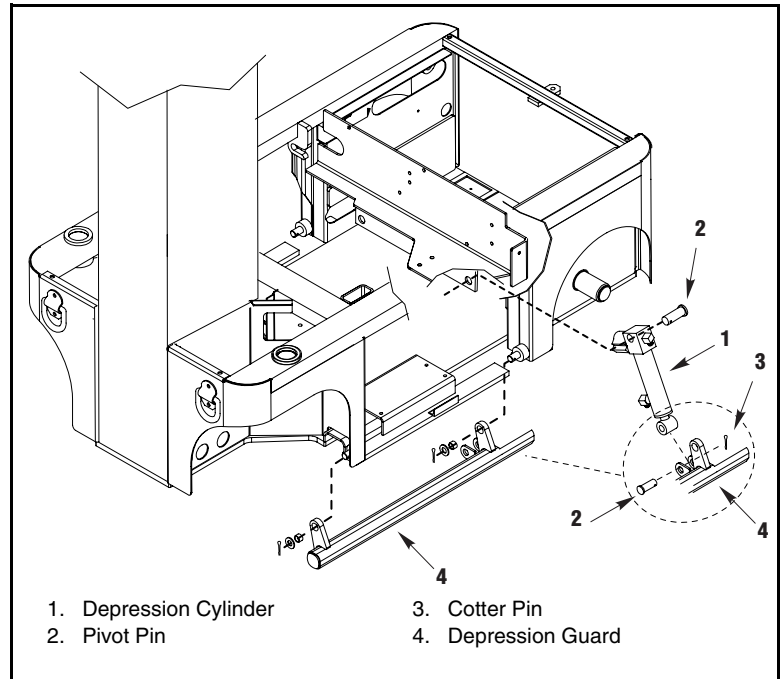

BRAKE CYLINDER

The brake cylinder is located inside the right rear chassis wall above the wheel.

Figure 3-11: Brake Cylinder, Remove & Replace

REMOVAL

1. Block the wheels to prevent the work platform from rolling when the brake is removed.
2. Use a 1000Kg (**one ton**) capacity jack to raise the rear of the machine. Position blocks under the machine to prevent the work platform from falling if the jack fails.
3. Block the front wheels to prevent the machine from rolling.
4. Remove the spring compression nut and flat washer from the tension bar.
5. Remove the retaining ring and right rear wheel.
6. Remove the cotter pin and pivot pin from the rear cylinder mount.
7. Remove the cotter pin from the tension bar pivot allowing the cylinder to be lowered.
8. Disconnect the hose assemblies and cap the openings to prevent foreign material from entering.
9. Remove the cylinder from the chassis.

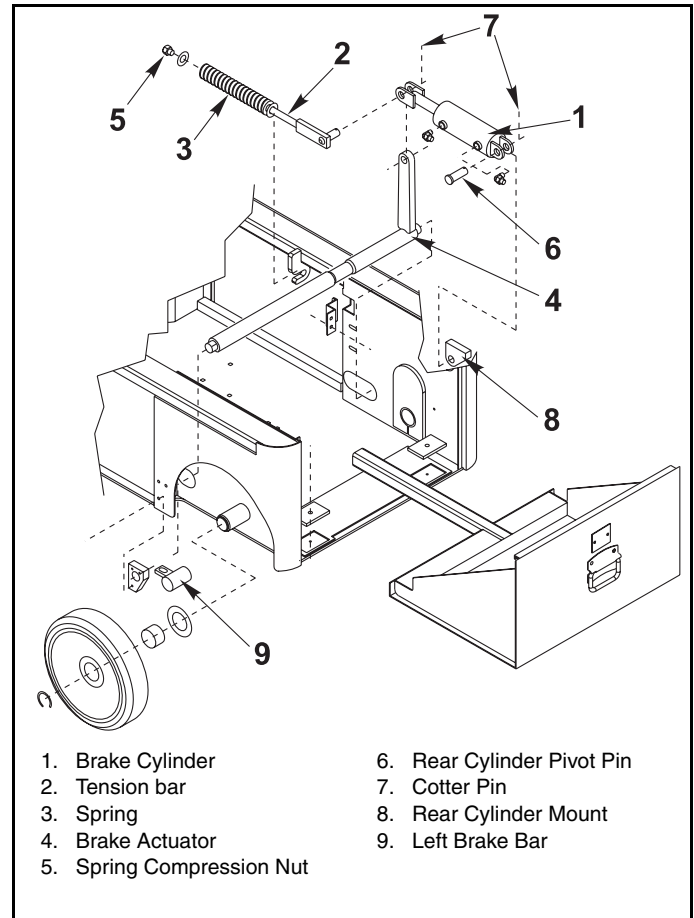

REPAIR

Refer to Cylinder Repair in Section 1 - General Information.

INSTALLATION

1. Connect the hose assemblies.
2. Install the tension bar pivot through the cylinder clevis and brake actuator and secure with a new cotter pin.
3. Install the pivot pin through the cylinder mounting tabs and rear cylinder mount and secure with a new cotter pin.
4. Install the wheel and retaining ring.
5. Install the flat washer and spring compression nut on the tension bar. Tighten the nut until at least flush with the tension bar shaft or until the brake bar has full engagement with the tire.
6. Lower the machine and operate the drive circuit and check that the brake bars retract and clear the tires when driving and fully engage the tires when stopped. Check for leaks

STEERING CYLINDER

REMOVAL

1. Mark and disconnect the hose assemblies from the cylinder fittings and immediately cap the openings to prevent foreign material from entering.
2. Remove the cotter pins from the pivot pins.
3. Remove the pivot pins while supporting the cylinder. Remove the cylinder.

REPAIR

Refer to Cylinder Repair in Section 1 - General Information.

INSTALLATION

1. Position the cylinder assembly in the chassis and insert pivot pins and secure with new cotter pins.
2. Connect the hose assemblies to the fittings.
3. Operate the steering circuit several times throughout its entire range of travel to expel trapped air and check for leaks.

Figure 3-12: Steering Cylinder Remove & Replace

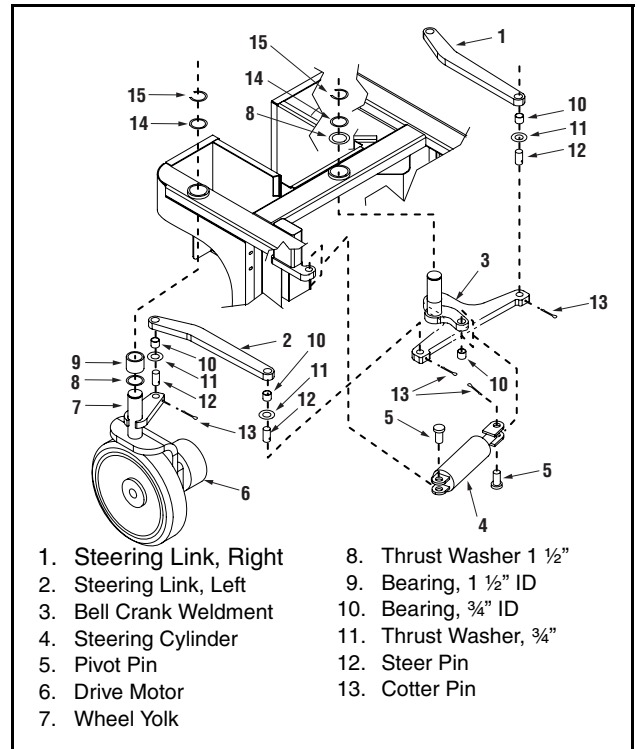
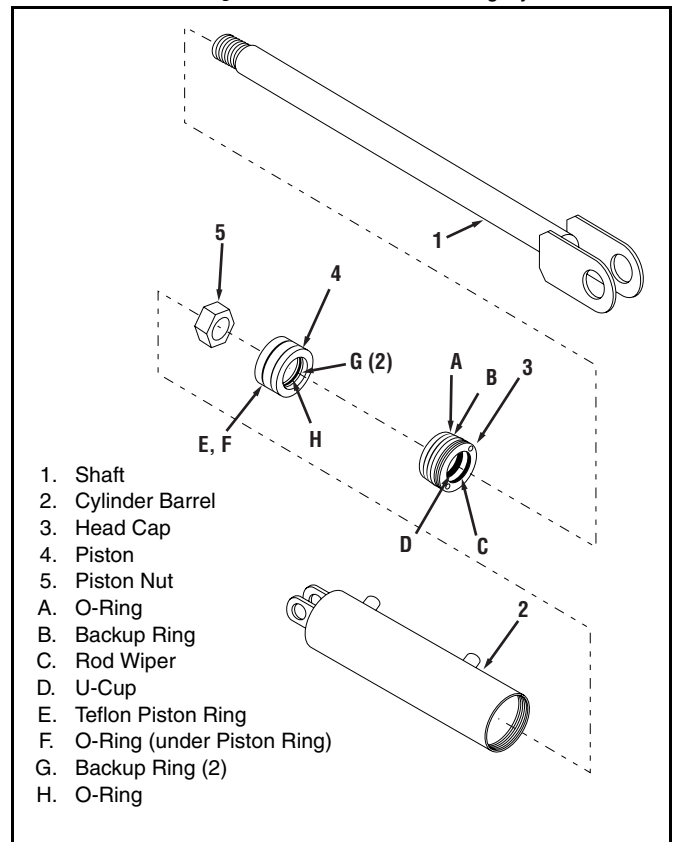

Figure 3-13: Brake and Steering Cylinder Seal Kit



LIFT CYLINDER

REMOVAL

Refer to Figure 3-16: "Elevating Assembly," on page Section 3-20 for details.

1. Fully lower platform.
2. Provide a suitable container to catch the hydraulic fluid, then disconnect the hydraulic hose. Immediately plug hoses to prevent foreign material from entering.
3. Remove the adapter from the base of the cylinder, inside the chassis.
4. Remove the Emergency Lowering Valve Knob from the valve at the base of the cylinder, then remove the Emergency Lowering Valve out the access hole in the bottom of the chassis.
5. Remove the snap ring at the bottom of the cylinder under the chassis.
6. Detach the 6.35mm (0.25 in.) vent line tubing from the top of the hydraulic tank, and cut any plastic ties that secure the tubing. Plug the end of the tubing to prevent contamination.
7. Remove the platform mast cover.
8. Remove the capscrew and locknut securing the cylinder rod to the upper cylinder mount.
9. Attach a suitable hoisting device and sling to the cylinder. Carefully lift the cylinder approximately 0.5 m (18 in.) until you can see the vent line tubing attached near the top of the cylinder barrel. Detach the tubing by depressing the green ring on the fitting at the same time you pull firmly on the tube. Plug the end of the tube and the fitting to prevent contamination.

10. Raise the cylinder the rest of the way through the top of the mast.

REPAIR

Refer to Cylinder Repair in Section 1 - General Information.

INSTALLATION

1. Attach a suitable hoisting device and sling to the cylinder. Carefully lower the cylinder through the top of the mast until you can reattach the vent line tubing. Simply push the tubing into the fitting until it goes no further. Pull firmly to ensure that it is installed correctly.
2. Lower the cylinder the rest of the way, and secure the cylinder to the chassis with the snap ring.
3. Install capscrew, washers and locknut securing cylinder rod to the upper cylinder mount.
4. Install platform mast cover.
5. Install the Emergency Lowering Valve, Knob and adapter to the base of the lift cylinder.
6. Remove the plug from the hydraulic hose and attach it to the adapter.
7. Attach the vent line to the hydraulic tank.
8. Test with weight at rated Platform load to check system operation. Check for leaks

Figure 3-14: Lift Cylinder Seal Kit

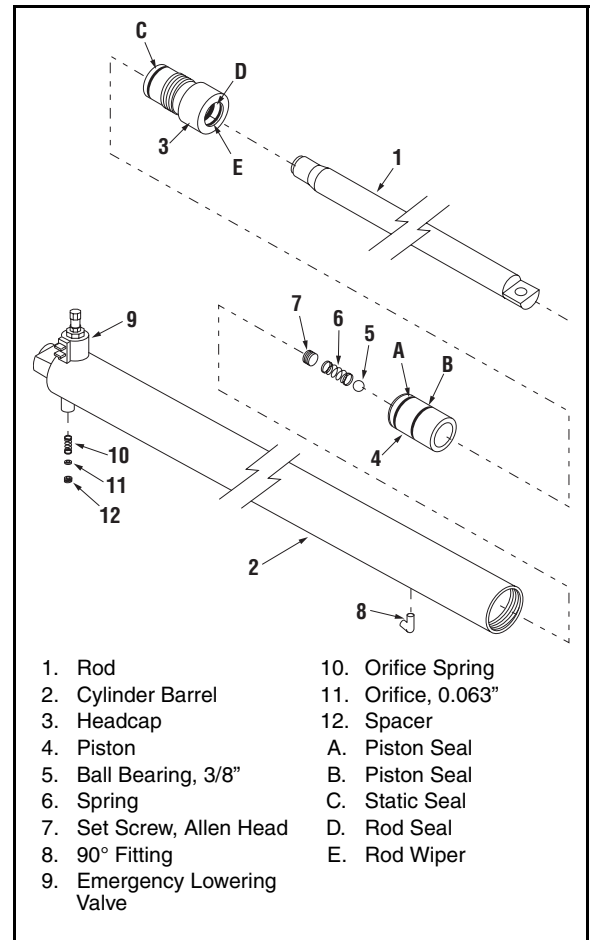

3-9 DRIVE MOTORS

REMOVAL

1. Use a 1000Kg (**one ton**) capacity jack to raise the front of the machine. Position blocks under the machine to prevent the work platform from falling if the jack fails.
2. Block the rear wheels to prevent the machine from rolling.
3. Remove the cotter pin, nut, and washer.
4. Remove the wheel.

NOTE: Before disconnecting hoses, thoroughly clean off all outside dirt around fittings. (After disconnecting hoses and before removing from vehicle, IMMEDIATELY plug port holes.)

5. Tag, disconnect and plug the hose assemblies to prevent foreign material from entering.
6. Support the drive motor/wheel yoke assembly and remove the retaining ring at the top of the wheel yoke pivot. Remove the drive motor/wheel assembly from the machine.
7. Remove the locknuts, flat washers, capscrews and drive motor from the wheel yoke.

INSTALLATION

1. Position the drive motor in the wheel yoke and secure with capscrews, flat washers and locknuts.
2. Install the drive motor/wheel yoke assembly into the pivot bearing along with the lower thrust washer, thrust bushing, and retaining ring.
3. Align the steer pin with the hole in the steering link.
4. Remove the plugs from the hose assemblies and connect to the drive motor.
5. Install the shaft key, wheel, washer and slotted nut. Torque the locknut to 102 N-m (**75 ft-lbs**). Install a new cotter pin. **DO NOT** back-off the nut to install cotter pin.
6. Remove blocks, lower the jack and remove. Operate the drive system and check for leaks.

Figure 3-15: Drive Motor Assembly

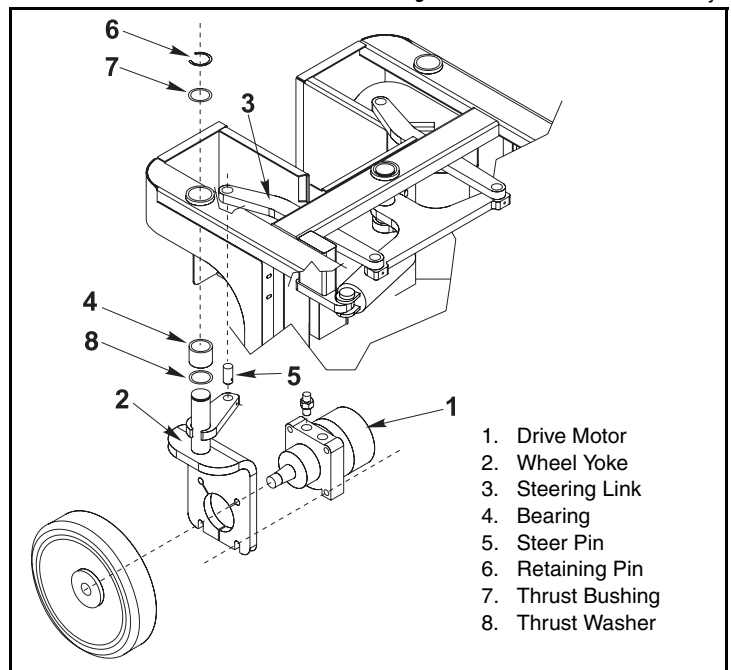

3-10 ELEVATING ASSEMBLY

Maintenance of the elevating assembly consists of four separate tasks and maintenance intervals:

- Chain Lubrication 6 months
- Elevating Assembly Wear Inspection 6 months
- Chain Tension Inspection 1 year
- Chain Elongation Inspection 5 years

All of the tasks except the Elongation Inspection can be done without removing the chains from the assembly.

Figure 3-16: Elevating Assembly

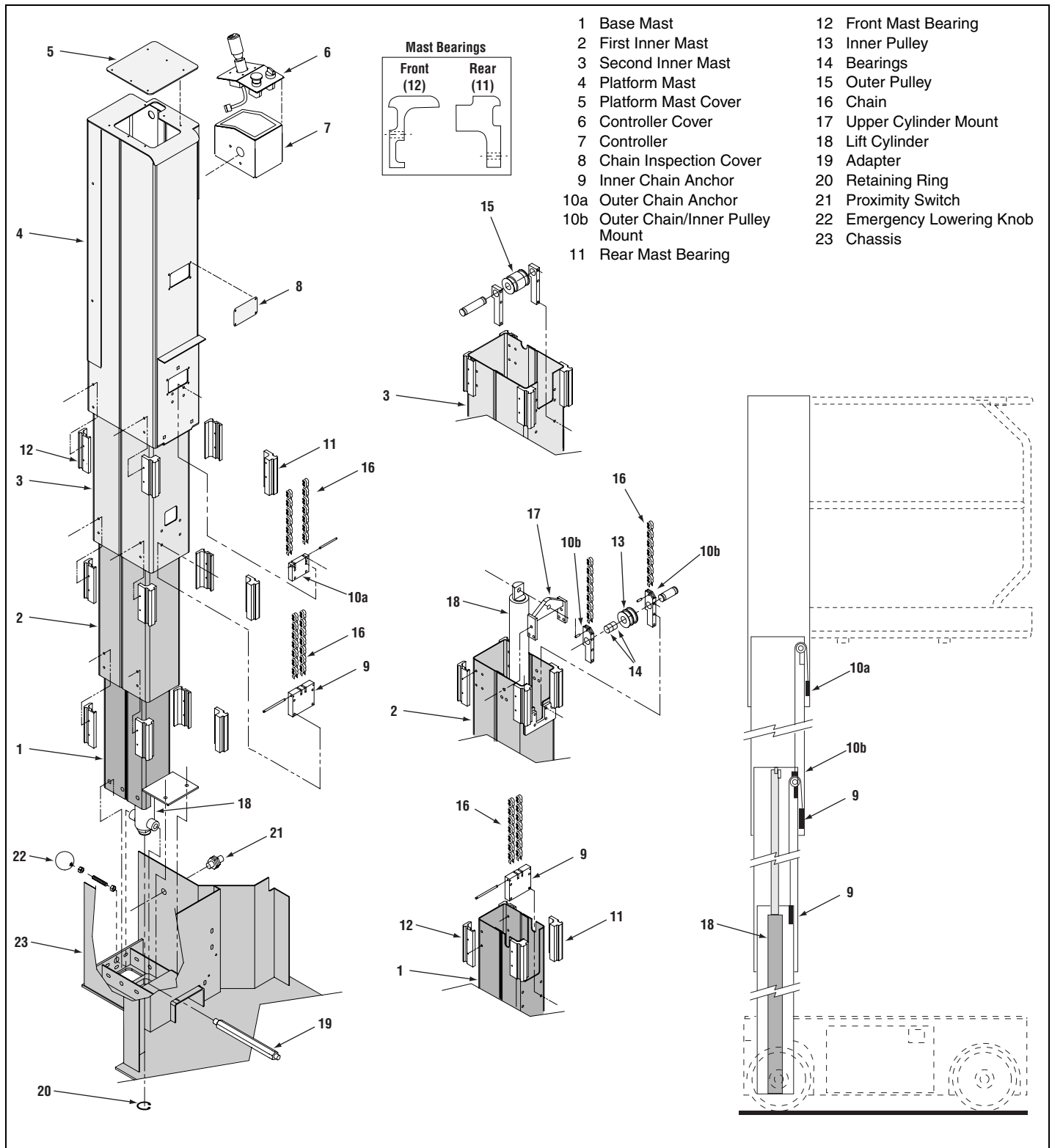

LIFT CHAIN LUBRICATION

Refer to Figure 0-16: "Elevating Assembly," on page Section 3-20.

With platform in the stowed position;

- remove the *platform mast cover* (5).
- apply enough aerosol chain lubricant to the exposed portion of all four chains to allow the lubricant to run down the chains.
- replace the cover.
- remove the chain inspection cover (8).
- raise platform approximately 10cm (4 in.), until the inner set of chains are visible through the chain inspection hole.
- apply enough aerosol chain lubricant to the exposed chain to allow the lubricant to run down the chain.
- replace chain inspection cover.

ELEVATING ASSEMBLY WEAR INSPECTION

Refer to Figure 0-16: "Elevating Assembly," on page Section 3-20.

At the same time as the chain lubrication task, inspect all elevating assembly components for wear.

With the platform in the stowed position;

- inspect the system through the *platform mast cover* (5) to look for worn *pulleys* (13 & 15) or damaged components.
- Inspect the *chain anchors* (10a & 10b) and visible portions of lift chain as you lubricate it.
- Look for cracks in the chain links, kinks in any portion of chain, and excessive corrosion.

From the lower controls, raise the platform and block the elevating assembly (see Figure 0-1: "Supporting Elevating Assembly," on page Section 3-3).

- Inspect the *inner chain anchors* (9) and the ends of the chains for damage or worn parts. If damage is present, replace the components.

IMPORTANT: There are two pairs of two chains each, for a total of four chains. If only one chain of either pair is damaged, both chains in the pair must be replaced.

CHAIN TENSION INSPECTION

Refer to Figure 0-16: "Elevating Assembly," on page Section 3-20.

The lifting chains are self-adjusting and should always be close to the same tension. This tension should be checked annually to ensure that there are no problems with this system. To do this task a spring scale will be needed with 20kg (**44 lb.**) capacity.

1. Place 227kg (**500 lbs.**) in the platform including the weight of the person testing the chain tension.
2. Remove the *chain inspection cover* (8) and raise the platform approximately 10cm (**4 in.**) until the outer inspection hole lines up with the inner inspection hole.
3. Attach the spring scale to one of the outer chains and pull until the chain makes contact with the inner surface of the mast section. Note the scale reading.
4. Repeat step 3 on the other outer chain.
5. Compare the scale readings. The readings for each chain in the outer set should be within 20% of each other.
6. Repeat steps 3 - 5 for the inner set of chains. The readings for each chain in the inner set should be within 20% of each other.

IMPORTANT: If the readings are not within 20%, then a problem exists that is causing unequal chain tension. Investigate the problem and repair or replace the worn components.

CHAIN ELONGATION INSPECTION

At five-year intervals, the chains should be removed from the mast and the entire length of the chain inspected for excessive wear and elongation. Follow the procedure below to disassemble the elevating assembly. With the lift chains removed, hang them vertically from something capable of holding 100kg (**220 lbs.**). Inspect the chains thoroughly, looking for cracks in the chain links, kinks in any portion of chain, and excessive corrosion. Complete the following elongation test:

1. Attach approximately 25kg (**55 lbs.**) to the lower end of each chain.
2. Measure the distance between 50 pins. This distance should be 63.5cm - 65.5cm (**25 in. - 25¾ in.**).
3. Remove the weight and measure the same on the other three chains.

If the chains have elongated beyond the indicated range, replace the lift chain sets. Before reinstalling the lift chains, take this opportunity to thoroughly clean and lubricate the entire chain. Reassemble the elevating assembly as described below.

Figure 3-17: Chain Elongation Inspection

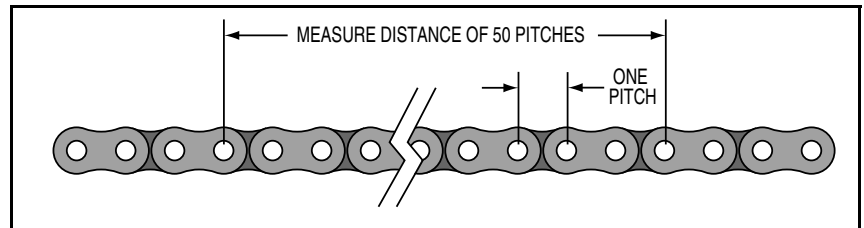

REMOVAL OF ELEVATING ASSEMBLY

Refer to Figure 0-16: "Elevating Assembly," on page Section 3-20.

1. Disconnect the batteries using the battery disconnect in front of the batteries in the battery tray.
2. Remove the *platform mast cover* (5), and the *controller cover plate* (6).
3. Detach the control cable inside the *controller* (7), remove the cable clamp in the top of the *platform mast* (4), and feed the cable into the *second inner mast* section (3).
4. Using a suitable hoisting device, carefully raise the *platform mast* (4) until you can access the *outer chain anchor* (10a).
5. Disconnect the *outer chain anchor* from the *platform mast*, but leave the anchor attached to the chains.
6. Remove the lower mast bearings from the *platform mast*. The front two mast bearings may be removed by drilling out the lower pop rivets that retain the bearings.
7. Raise the *platform mast* straight up and off of the remaining mast sections.
8. Lay the chain that was detached from the *platform mast* over the top of the *upper cylinder mount* (17), and place it down inside the *second inner mast* section.
9. Repeat steps 4 - 7 on the *second inner mast* section (3). The lower mast bearings are removed by unscrewing the two screws on each bearing.
10. The upper chain set may now be removed by detaching the *upper chain/inner pulley mounts* from the *first inner mast* section (2). Carefully set the chain set aside on a clean surface.
11. Remove the single bolt that attaches the *cylinder* to the *upper cylinder mount* (17).
12. Using a suitable hoisting device, carefully raise the *first inner mast* section (2) up several inches.
13. Lay the remaining chain set over the top of the *cylinder*, and place it down inside the inner mast section.
14. Remove the lower mast bearings from the *first inner mast* section.
15. Raise the *first inner mast* section straight up and off of the remaining *base mast* section.
16. The inner chain set may now be removed.
17. If it is necessary to remove the *base mast* section, remove the nine bolts that secure it to the *chassis*. It may be required to remove the *lift cylinder* to provide easier access to the bolts (see "Lift Cylinder" on page Section 3-18).

INSTALLATION OF ELEVATING ASSEMBLY

Refer to Figure 0-16: "Elevating Assembly," on page Section 3-20.

Installation of the elevating assembly is the reverse of removal.

- Torque the nine bolts that retain the *base mast* section to 68N-m (**50 ft-lbs**).
- For all of the cap screws that attach the chain anchors to the mast sections, apply Loctite #242 to the screw threads and torque to 12N-m (**107 in-lbs**).
- For all of the screws that attach the mast bearings, apply Loctite Retainer #405 to the screw threads. *Do not torque, simply tighten securely.*
- Check elevating assembly for proper operation.

3-11 TILT SENSOR

! WARNING !

Never perform service on the work platform in the elevating assembly area while platform is elevated without first blocking the elevating assembly.

DO NOT stand in elevating assembly area while deploying or storing brace.

The Tilt Sensor has three wires; red-power (24v in), black-ground, white-output (24v out). To verify the sensor is working properly, there is one red LED under the sensor. If the LED is on, the sensor is off level.

ADJUSTMENT

1. Place machine on firm level surface $\pm 1/4^\circ$.
2. Use the Inclinator (p/n 010119-000) to ensure front and rear of Chassis is level $\pm 1/4^\circ$.
3. Adjust the three leveling screws until the bubble is centered in the circle on the attached bubble level.

TEST

1. Raise the platform approximately 2m (7 ft.).
2. Support the elevating assembly (see "Supporting Elevating Assembly" on page Section 3-3).
3. Push the level sensor to the side.

The red LED should turn on, and the tilt alarm should sound.

Figure 3-18: Tilt Sensor

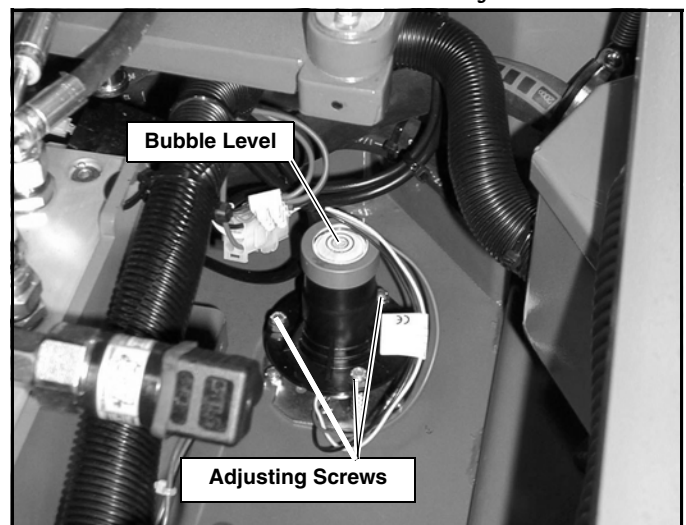

3-12 CONTROLS

PLATFORM CONTROLS

The Proportional Controller can be disassembled to replace defective switches. See the Parts Manual for replacement part numbers.

Figure 3-19: Upper Controls

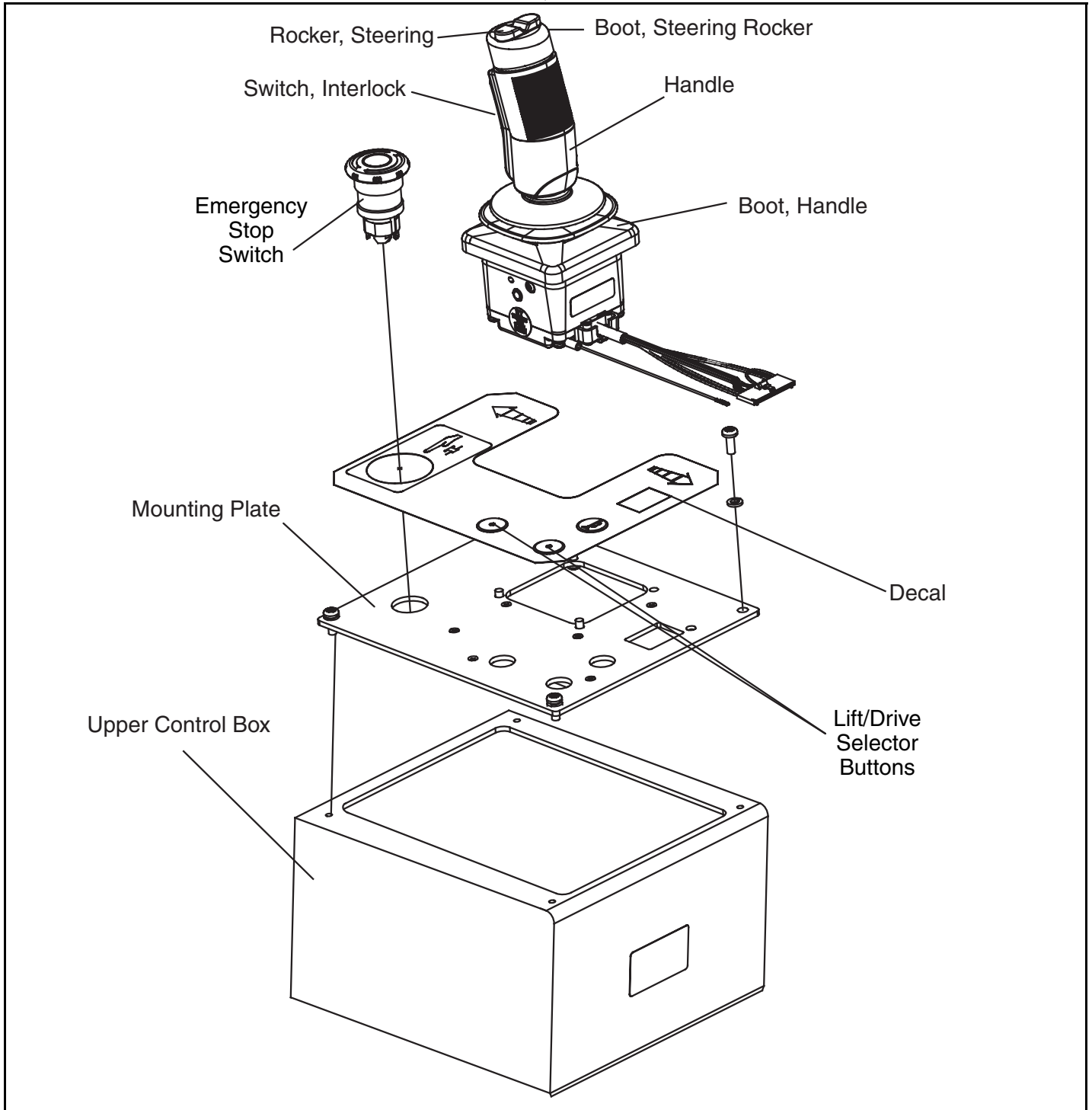

CHASSIS CONTROLS

The chassis control assembly is mounted on the inside of the chassis door, to the left of the Hydraulic tank.

Figure 3-20: Chassis Controls

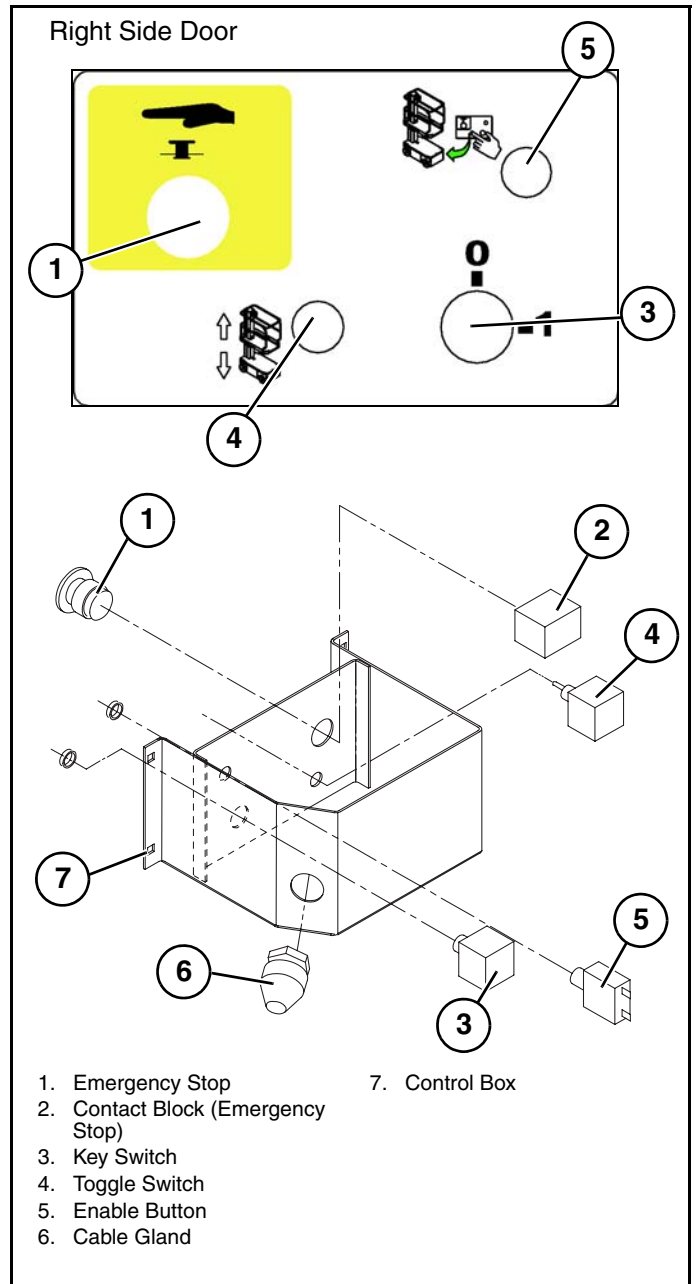

TROUBLESHOOTING

4.1 INTRODUCTION

The following section on troubleshooting provides guidelines on the types of problems users may encounter in the field, helps determine the cause of problems, and suggests proper corrective action.

Careful inspection and accurate analysis of the symptoms listed in the Troubleshooting Guide will localize the trouble more quickly than any other method. This manual cannot cover all possible problems that may occur. If a specific problem is not covered in this manual, call our number for service assistance.

Referring to Section 2.0 and 5.0 will aid in understanding the operation and function of the various components and systems and help in diagnosing and repair of the machine.

GENERAL PROCEDURE

Thoroughly study hydraulic and electronic schematics in **Section 5**. Check for loose connections and short circuits. Check/repair/replace each component in the Truth Table that is listed under each machine function that does not operate properly.

Use the charts on the following pages to help determine the cause of a fault.

NOTE: Spike protection diodes at components have been left out of the charts to eliminate confusion.

W A R N I N G

When troubleshooting, ensure that the work platform is resting on a firm, level surface.

When performing any service that requires the platform to be raised, ensure that the platform and booms are supported by a crane capable of supporting the load.

Unplug the machine or disconnect the battery when replacing or testing the continuity of any electrical component.

4.2 TROUBLESHOOTING

1. Verify your problem.
 - Do a full function test from both the platform and chassis controls, and note all functions that are not operating correctly.
2. Narrow the possible causes of the malfunction.
 - Use the troubleshooting guide to determine which components are common to all circuits that are not functioning correctly.
3. Identify the problem component.
 - Test components that are common to all circuits that are not functioning correctly. Remember to check wires and terminals between suspect components. Be sure to check connections to battery negative.
4. Repair or replace any component found to be faulty.
5. Verify that repair is complete.
 - Do a full function test from both the platform and chassis controls to verify that all functions are operating correctly and that the machine is performing to specified values.

SPECIAL TOOLS

Following is a list of tools which may be required to perform certain maintenance procedures on the TM12 work platforms.

- Flow Meter with Pressure Gauge (UpRight P/N 067040-000)
- 0-69 bar (0-1000 psi) Hydraulic Pressure Gauge with Adapter Fittings (UpRight P/N 014124-010)
- 0-207 bar (0-3000 psi) Hydraulic Pressure Gauge with Adapter Fittings (UpRight P/N 014124-030)
- Adapter Fitting (UpRight P/N 063965-002)
- Inclinator (UpRight P/N 010119-000)
- Crimping Tool (UpRight P/N 028800-009)
- Terminal Removal Tool (UpRight P/N 028800-006)

ADJUSTMENT PROCEDURES

Hydraulic settings must be checked whenever a component is repaired or replaced.

Remove counterbalance valves and "bench test" them if they are suspect.

Connect a pressure gauge of appropriate range to the test port located on the hydraulic manifold.

Correct pressure settings are listed in the hydraulic schematic.

CHECKING PUMP PRESSURES

Remove hose from pump port and connect pressure gauge.

4.3 TROUBLESHOOTING GUIDE

TROUBLE	PROBABLE CAUSE	REMEDY
All functions inoperable, electric motor does not start.	<ol style="list-style-type: none"> 1. Blown electric motor fuse 2. Faulty battery charger. 3. Faulty battery(ies). 4. Loose or broken battery lead. 5. Emergency Stop switch(es) failed open. 6. Blown control fuse 	<p>Check 160 amp electric motor fuse. Replace if blown.</p> <p>Check the voltage output of the battery charger. If less than 24 VDC,</p> <p>After completely charging batteries, test each battery. Replace as</p> <p>Check continuity of all battery and motor leads. Replace if necessary.</p> <p>With emergency stop switch in the ON position, check continuity</p> <p>Check 7A circuit control fuse. Replace if blown.</p>
All functions inoperable. Electric motor starts when control is actuated.	<ol style="list-style-type: none"> 1. Oil level in hydraulic reservoir is low. 2. Faulty hydraulic pump. 	<p>Check hydraulic fluid level, top off as required.</p> <p>Check pressure and delivery of the hydraulic pump. Replace if</p>
Platform will not elevate or elevates slowly.	<ol style="list-style-type: none"> 1. Emergency Lowering valve open. 2. Platform overloaded. 3. Faulty controller at upper controls. 4. Blown control fuse 5. Battery level low. Check for fault code 68 	<p>Close emergency down valve.</p> <p>Observe maximum load rating. (see Operation section of this manual)</p> <p>Check functionality of controller. Replace if faulty.</p> <p>Check 7A circuit control fuse. Replace if blown.</p> <p>Check Battery Voltage. Charge if necessary.</p>
Platform drifts down after being elevated	<ol style="list-style-type: none"> 1. Emergency lowering valve open. 2. Leaking piston seals in lift cylinders 	<p>Ensure that emergency lowering valve is completely closed. Replace</p> <p>Check for leakage at cylinder return line, replace seals if necessary.</p>

4.4 FAULT CODES INTRODUCTION

The TM12 is equipped with a fault detection system, if you have a faulty component, bad electrical connection or start up error a fault code will be displayed on the read out located on the upper control box.

For fault codes 01 - 39 the following procedure should be followed.

Ensure that no selector buttons are depressed.

Ensure that the deadman switch on the joystick is not held.

Ensure that the joystick is in neutral.

Ensure that the steer rocker is not activated.

Ensure that analog rocker is in neutral.

Then re-cycle power, do this by pushing and releasing the emergency stop button. If the fault code is still displayed you may have a faulty upper or lower control box, consult the error code list to identify the problem component and replace if necessary.

For fault codes 54 - 68 the following procedure should be followed.

1. Check the fault code list to identify the problem component.
2. Ensure that the wiring harness is connected, secure, in good condition and fully intact.
3. Ensure that the problem component is receiving electrical signal, consult the schematics in section 6 of this manual to identify the ECU output and harness test points.
4. If no ECU output is present replace the ECU.
5. If ECU output is present but no signal is reaching the component replace the wiring harness.
6. If signal is reaching the component but the component is not functioning replace the component (refer to section 6 of this manual for part number information).

4.5 FAULT CODES

- 01 – System initialization error
- 02 – System communication error
- 22 – Platform Left Turn Switch ON at power-up
- 23 – Platform Right Turn Switch ON at power-up
- 25 – Platform Hi-Drive Switch ON at power-up
- 27 – Platform Lo-Drive Switch ON at power-up
- 28 – Platform Lift Switch ON at power-up
- 29 – Platform Joystick Enable Switch ON at power-up
- 31 – Platform Joystick not in neutral at power-up
- 32 – Lower Control Up/DownToggle ON at power-up
- 39 – Lower Control Enable Switch ON at power-up

- 54 – Pothole Retract Coil fault
- 55 – Lift Up Coil fault
- 56 – Lift Down Coil fault
- 59 – Steer Right Coil fault
- 61 – Steer Left Coil fault
- 66 – Forward Coil fault
- 67 – Reverse Coil fault

- 68 – Low Battery fault

4-6 ELECTRIC

Table 4-1: Electrical Troubleshooting Table

Component	Function	Lower Controls	Upper Controls	Drive Forward	Drive Reverse	High Speed/Creep	Raise Platform	Lower Platform	Steer Left	Steer Right	Depression Mechanism Extend	Depression Mechanism Retract	Brakes	Tilt Alarm	Down Alarm	Battery Charge
Alarm																
Batteries		X	X	X	X	X	X	X	X	X	X	X	X	X	X	
Battery Charger																X
5 AMP Circuit Breaker		X	X	X	X	X	X	X	X	X	X	X	X	X	X	
175 AMP Fuse		X	X	X	X	X	X	X	X	X	X	X	X			
ECU		X	X	X	X	X	X	X	X	X	X	X	X	X	X	
Motor Control		X	X	X	X	X	X	X	X	X	X	X	X			
Motor				X	X	X	X	X	X	X	X	X	X			
Chassis Emergency Stop Switch		X	X	X	X	X	X	X	X	X	X	X	X	X	X	
Chassis Key Switch		X	X	X	X	X	X	X	X	X	X	X	X	X	X	
Platform Emergency Stop Switch		X	X	X	X	X	X	X	X	X	X	X	X	X	X	
Interlock Switch			X	X	X	X	X	X	X	X						
PQ Control Handle			X	X	X		X	X								
Height Limit Switch							X									
Platform Steering Switch									X	X						
Tilt Sensor		X	X	X	X	X	X	X	X	X	X	X	X	X	X	
Steering Solenoid (right)										X						
Steering Solenoid (left)									X							
Platform Lift Solenoid							X									
Down Solenoid								X								
Reverse Solenoid					X											
Forward Solenoid				X												

4-7 HYDRAULIC

Table 4-2: Hydraulic Troubleshooting Table

Component	Function	Lift Platform	Lower Platform	Steer Right	Steer Left	Drive Forward	Drive Reverse	Creep	Depression Mechanism Extend	Depression Mechanism Retract	Brakes
Check Valve									X	X	
Steering Cylinder				X	X						
Lift Cylinder--CYL1		X									
Depression Mechanism Cylinder									X	X	
Brake Cylinder											X
Suction Strainer		X		X	X	X	X	X	X	X	
Return Filter		X		X	X	X	X	X	X	X	
Drive Motors (2)						X	X				
Pump		X		X	X	X	X	X	X	X	
Main Relief Valve		X				X	X	X	X	X	X
Steering Relief Valve				X	X						
Lift Relief Valve		X									
Tank											
Steering Right/Left Valve				X	X						
Lift Valve		X									
Down/Emergency Lowering Valve			X								
Forward/Reverse Valve						X	X				
Counterbalance Valve						X	X	X			X

Notes :

SCHEMATICS

5.1 INTRODUCTION

This section contains electrical and hydraulic power schematics and associated information for maintenance purposes.

The diagrams are to be used in conjunction with the information in **Section 4**. They allow understanding of the makeup and functions of the systems for checking, tracing, and faultfinding during troubleshooting analysis.

CONTENTS

Schematic (J1 Harness)	5-2
Cable Assembly (J1 Harness)	5-3
Electrical Schematic	5-4
Hydraulic Schematic	5-5

5.3 CABLE ASSEMBLY

WIRE INFORMATION

TABLE 1

ITEM NO.	POSITION	COLOR	ITEM NO.	POSITION	COLOR	ITEM NO.	POSITION	COLOR
1	A1	YELLOW, FROM ITEM 85	13	B1	ORANGE, FROM ITEM 85	25	C1	BROWN, FROM ITEM 85
2	A2	BLACK, FROM ITEM 95	14	B2	RED, SINGLE WIRE	26	C2	WHI, SINGLE WIRE
3	A3	BLACK, SINGLE WIRE	15	B3	BLUE, SINGLE WIRE	27	C3	PINK, FROM ITEM 88C
4	A4	NOT USED	16	B4	PINK, FROM ITEM 88B	28	C4	GRAY, FROM ITEM 88B
5	A5	ORANGE, SINGLE WIRE	17	B5	BLACK, SINGLE WIRE	29	C5	GRAY, FROM ITEM 88A
6	A6	PINK, FROM ITEM 89a	18	B6	LIGHT BLUE, SINGLE WIRE	30	C6	WHITE/BLUE, SINGLE WIRE
7	A7	WHITE/BLACK, SINGLE WIRE	19	B7	BLUE/BLACK, SINGLE WIRE	31	C7	ORANGE, SINGLE WIRE
8	A8	WHITE, SINGLE WIRE	20	B8	BLACK, SINGLE WIRE	32	C8	GRAY, FROM ITEM 88C
9	A9	NOT USED	21	B9	RED, SINGLE WIRE	33	C9	BLACK, SINGLE WIRE
10	A10	RED, SINGLE WIRE	22	B10	BLUE, SINGLE WIRE	34	C10	BLUE/PURPLE, SINGLE WIRE
11	A11	BLACK/ORANGE, SINGLE WIRE	23	B11	PINK HI, FROM ITEM 89a	35	C11	GRAY HI, FROM ITEM 89a
12	A12	GRAY HI, FROM ITEM 89b	24	B12	BLUE, SINGLE WIRE	36	C12	PINK HI, FROM ITEM 89b

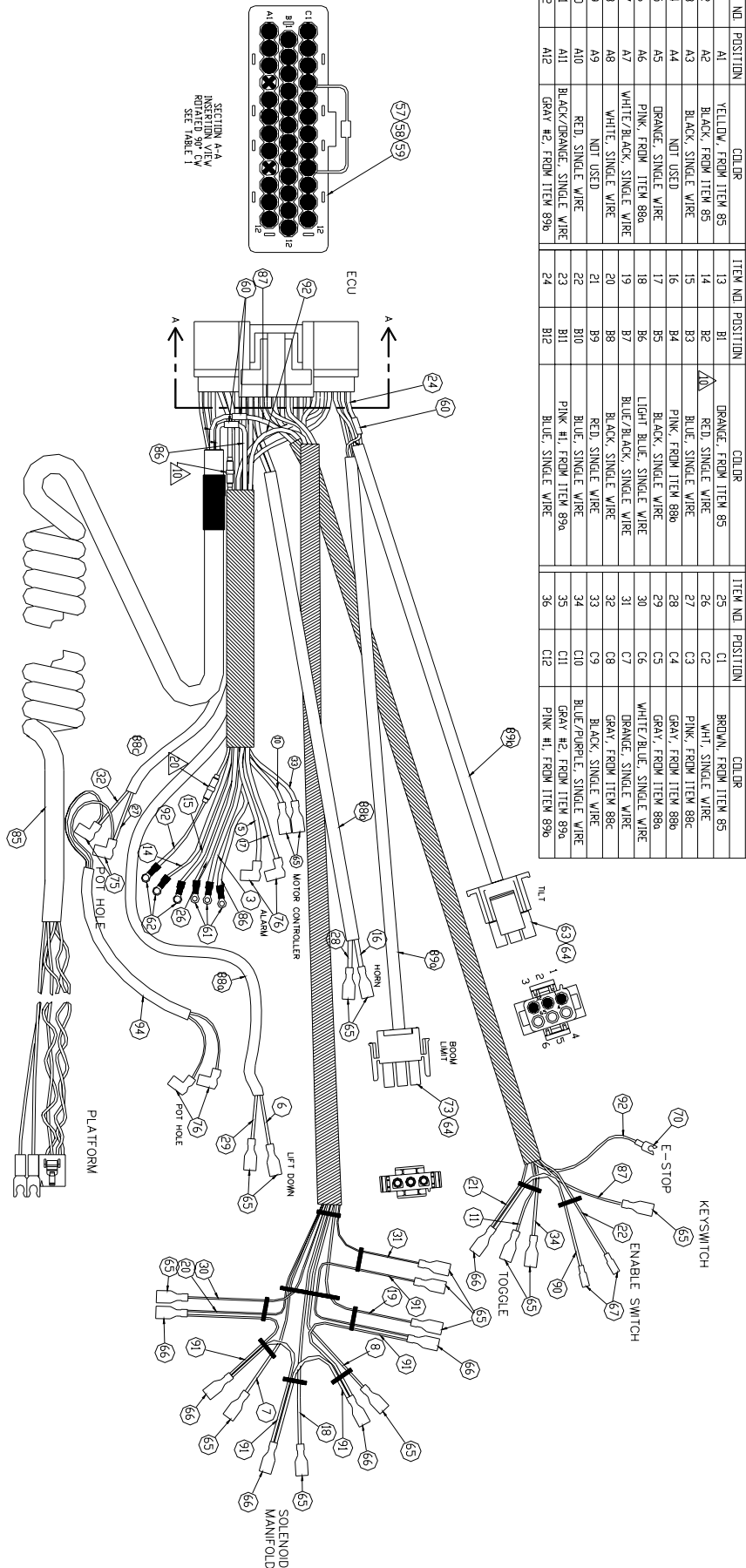

5.5 HYDRAULIC SCHEMATIC

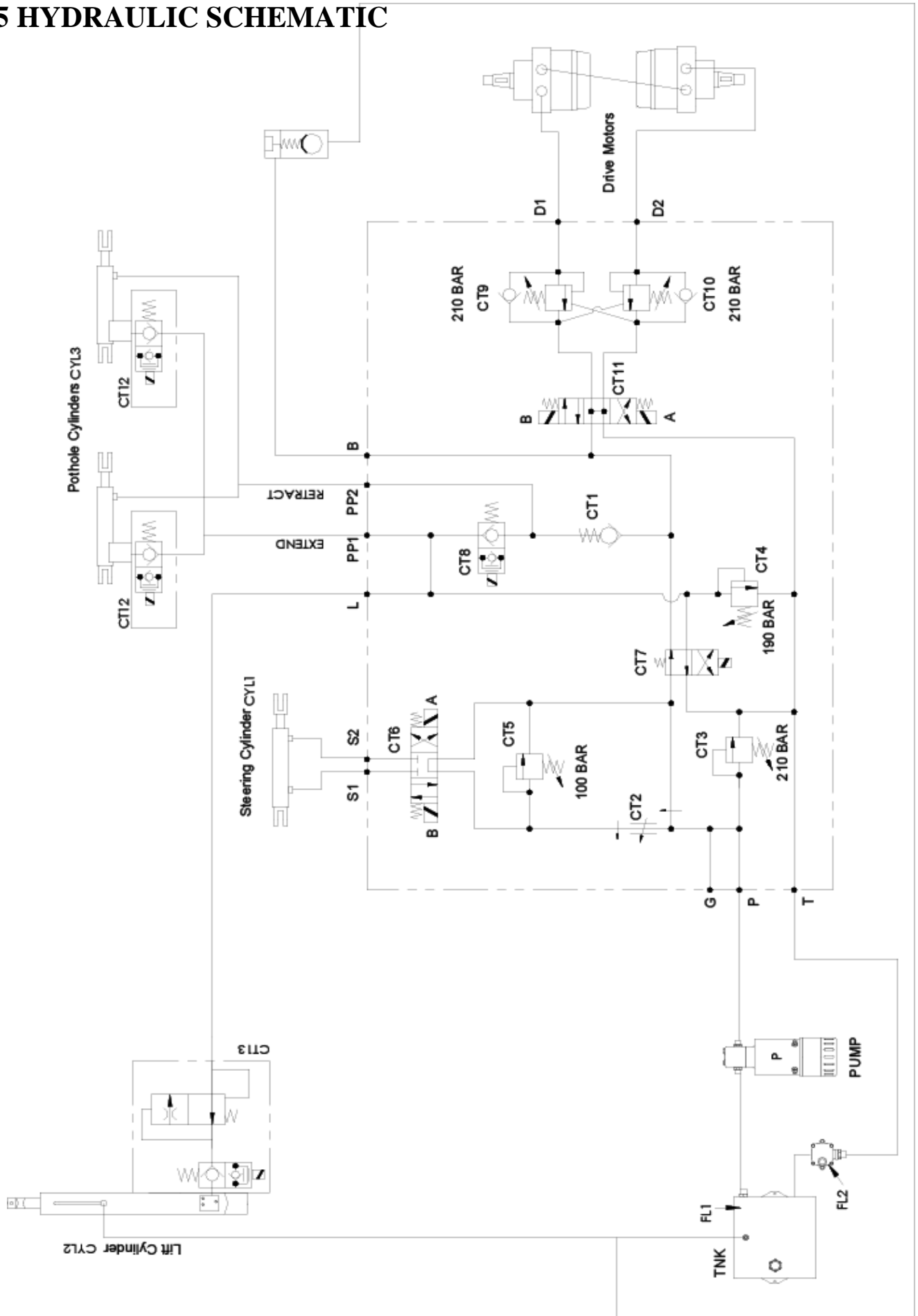

Notes :

ILLUSTRATED PARTS BREAKDOWN

6.1 INTRODUCTION

This section lists and illustrates the replaceable assemblies and parts of this product, as manufactured by UpRight Powered Access.

Each parts list contains the component parts for that assembly.

CONTENTS

General Assembly.	6 - 2	Hydraulic Assembly.	6 - 18
Chassis Assembly.	6 - 4	Hydraulic Cylinder Assembly (Lift)	6 - 21
Mast Assembly.	6 - 8	Hydraulic Cylinder Assembly (Steer / Brake).	6 - 22
Platform Assembly.	6 - 10	Hydraulic Cylinder Assembly (Pothole).	6 - 23
Control Valve Assembly.	6 - 12	Electrical Assembly	6 - 24
Lower Controls Assembly.	6 - 14	Decal Kit (English).	6 - 26
Hydraulic Tank Assembly.	6 - 15	Decal Kit (German).	6 - 28
Upper Controls Assembly	6 - 16	Decal Kit (French).	6 - 30
		Decal Kit (USA).	6-32

Illustrated Parts Breakdown - General Assembly

General Assembly

505000-000

Item	Part	Description	QTY.
1	505001-000	CHASSIS ASSEMBLY	1
2	505002-000	MAST / PLATFORM ASSEMBLY	1
3	505004-000	DECAL ASSEMBLY	1
4	505007-000	HYDRAULIC ASSEMBLY	1
5	505008-000	ELECTRICAL ASSEMBLY	1

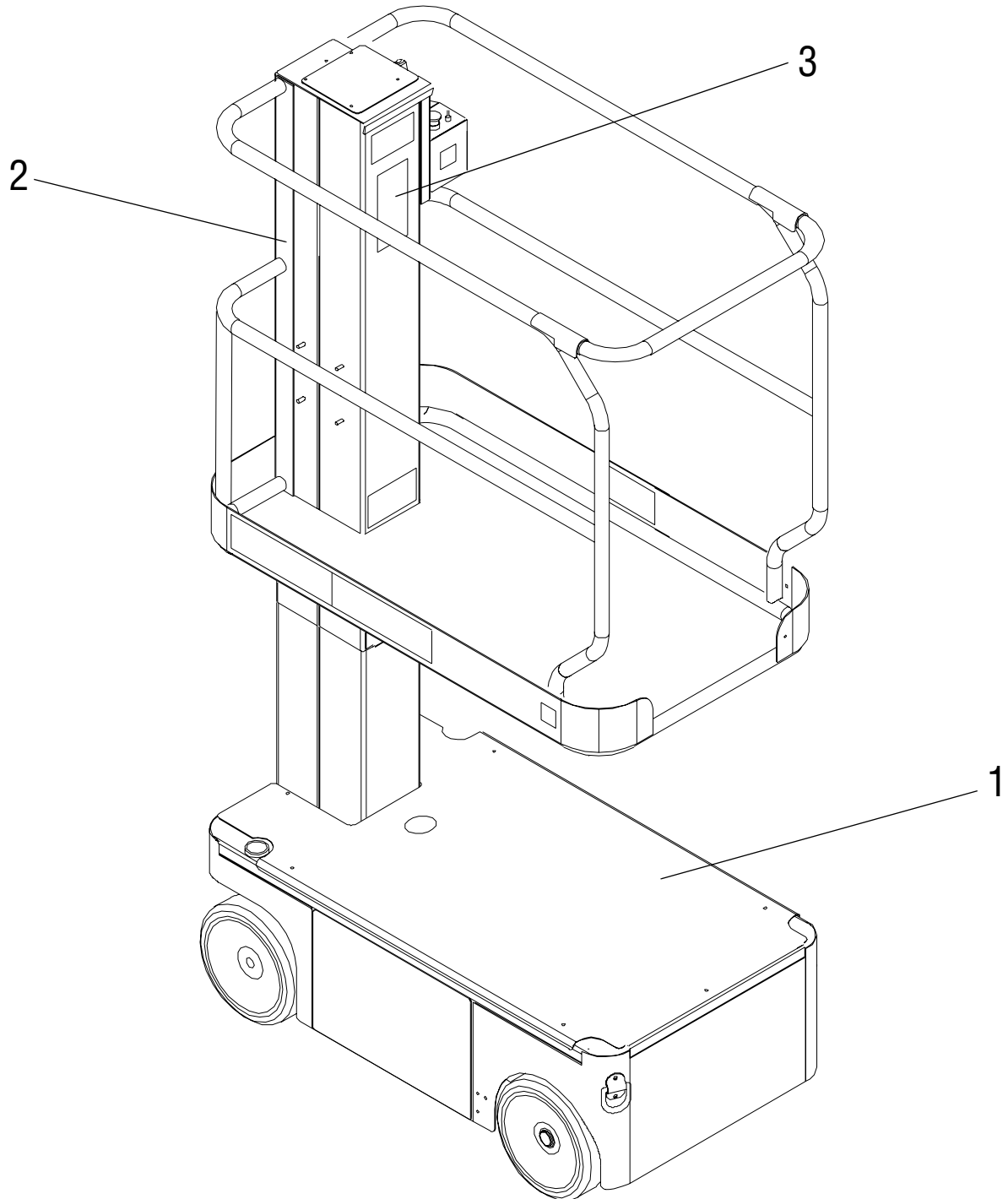

Chassis Assembly 1 of 4

505001-000

ITEM	PART NUMBER	DESCRIPTION	QTY
1	107133-000	CHASSIS WELDMENT TM12	1
2	065465-000	BATTERY PAN WELDMENT	1
3	065472-000	SHOE PARK BRAKE	2
4	505031-001	BRAKE BEARING (RH) & (LH)	2
5	N/A	N/A	N/A
6	107131-002	CHASSIS ACCESS PANEL	1
7	505033-001	BRACKET, SIDE PANEL SUPPORT	1
8	505029-000	FRONT COVER	1
9	505023-000	SPRING COMPRESSION	1
10	065474-000	TENSION BAR WELDMENT	1

ITEM	PART NUMBER	DESCRIPTION	QTY
11	505035-000	CYLINDER ASSY (BRAKE)	1
-	505035-010	SEAL KIT, CYLINDER	
12	065469-000	BRAKE ACTUATOR WELDMENT	1
13	505032-000	GUIDE PAD	2
14	505030-000	SLIDE PAD	2
15	026541-016	HANDLE	1
16	011848-019	PIVOT PIN, BRAKE CYLINDER	1
17	505028-000	SPACER PLATE, BATTERY TRAY SECURING PIN	1
18	505048-000	MAIN CHASSIS COVER	1

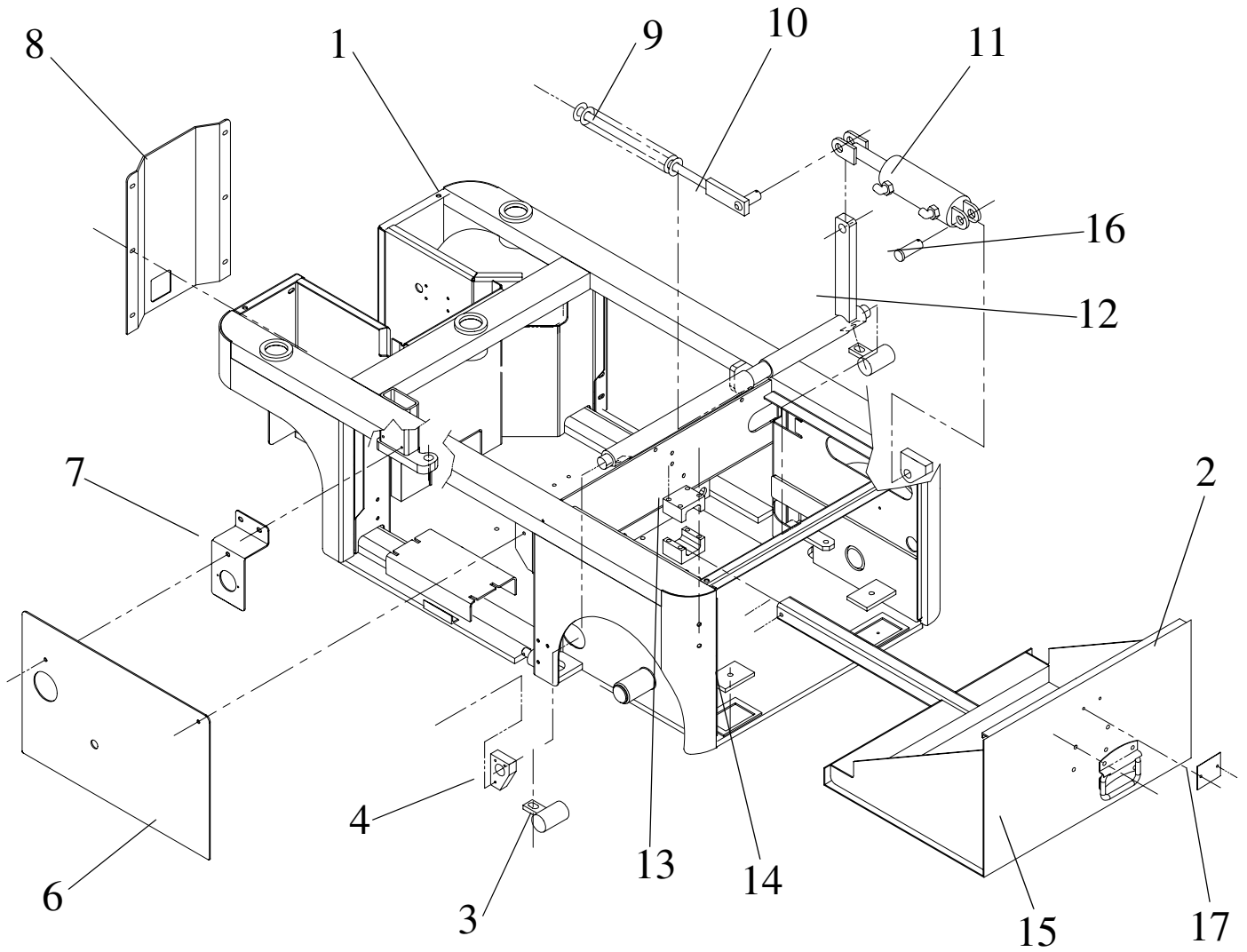

Chassis Assembly 2 of 4

505001-000

ITEM	PART NUMBER	DESCRIPTION	QTY
19	501999-000	MOTOR HYDRAULIC	2
*	101125-010	SEAL KIT (MOTOR)	2
20	505011-000	WHEEL, DRIVE	2
21	107186-000	WHEEL YOKE, L.H.	1
22	107185-000	WHEEL YOKE, R.H.	1
23	065517-000	STEER LINK RH	1
24	065518-000	STEER LINK LH	1
25	065445-000	BELL CRANK WELDMT	1
26	505035-000	CYLINDER ASSY, BRAKE/STEER	1
-	505035-010	SEAL KIT, BRAKE/STEER CYLINDER	-
27	505043-000	BUSHING, BELL CRANK & STEER YOKE PIVOT	3
28	500924-001	BUSHING (FLAT), BELL CRANK & STEER YOKE PIVOT	3
29	503673-000	BUSHING, STEERING LINK ARMS & BELL CRANK WELD'M	5
30	505034-000	PIVOT PIN, STEERING LINK ARMS	4
31	011848-019	PIVOT PIN, STEERING CYLINDER	2
32	505040-000	RETAINING RING, WHEEL YOKE PIVOT	2
33	505038-000	CIRCLIP	2
34	505045-000	SPACER (STEERING LINK)	4
35	502180-002	CASTLE NUT, (DRIVE WHEELS)	2
36	505116-000	WASHER (STEERING LINKARMS)	4
37	056058-016	M6 X 16 HEX HEAD SCREW	4
38	058819-000	GREASE NIPPLE	3
39	505075-000	SPACER	1

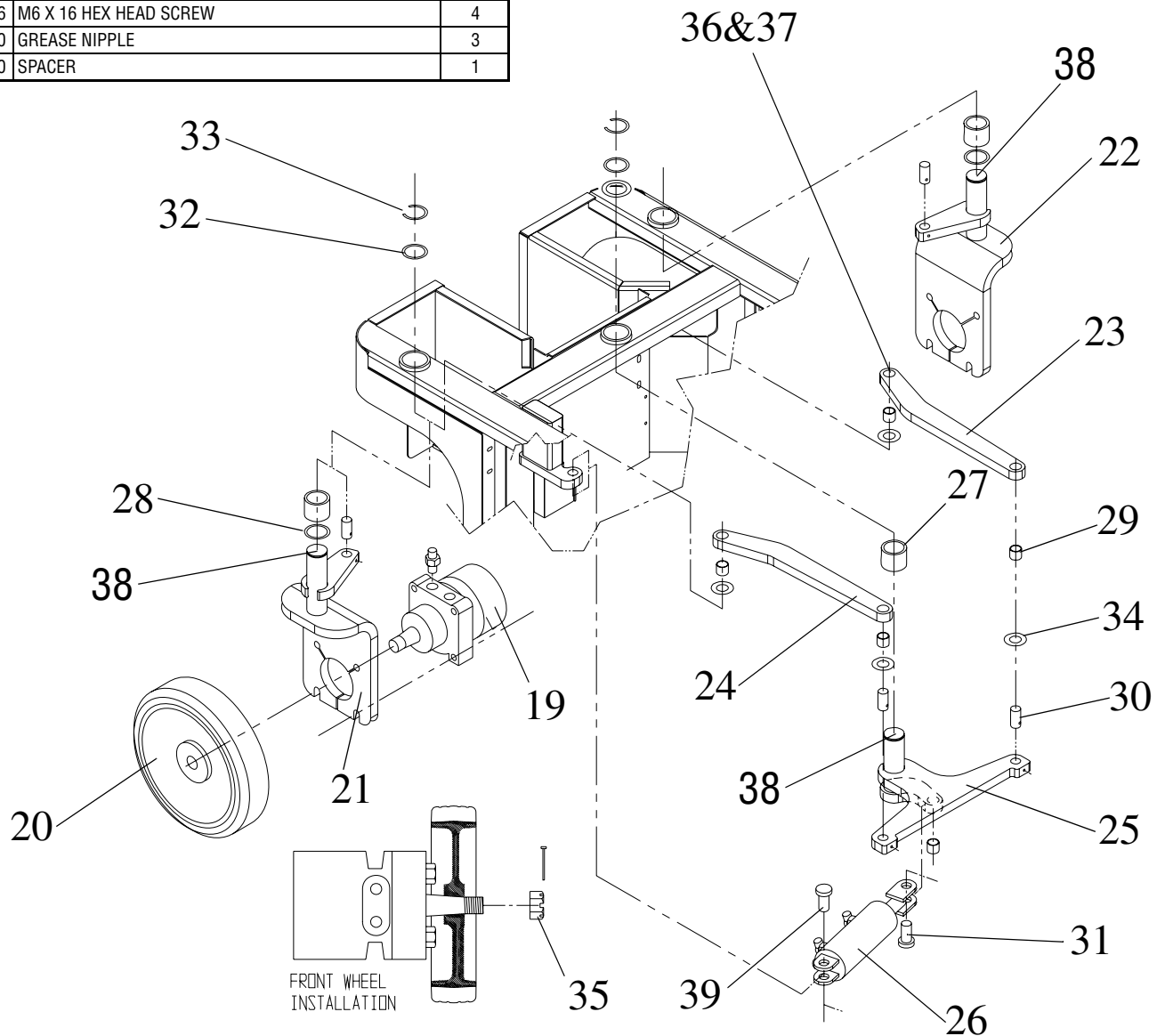

Chassis Assembly 3 of 4

505001-000

ITEM	PART NUMBER	DESCRIPTION	QTY
40	107133-000	CHASSIS WELDMENT	REF
41		PUMP UNIT (PUMP MOTOR)	1
42	501814-000	VIBRATION MOUNT	4
43	505024-000	LATCH (HINGING DOOR)	1
44	505021-000	DOOR (HINGED)	1
45	505025-000	HINGE	1
46	505013-000	TANK, (HYDRAULIC RESERVOIR)	1
47	503800-001	HYDRAULIC MANIFOLD BLOCK	1
48	107152-000	MOUNTING PLATE, HYDRAULIC MANIFOLD	1
49	505012-000	IDLER WHEEL	2
50	505041-000	BUSHING, SPACER	4
51	505038-000	CIRCLIP	2
52	505027-000	CIRCLIP COVER	2
53	504536-000	PUMP MOTOR	1

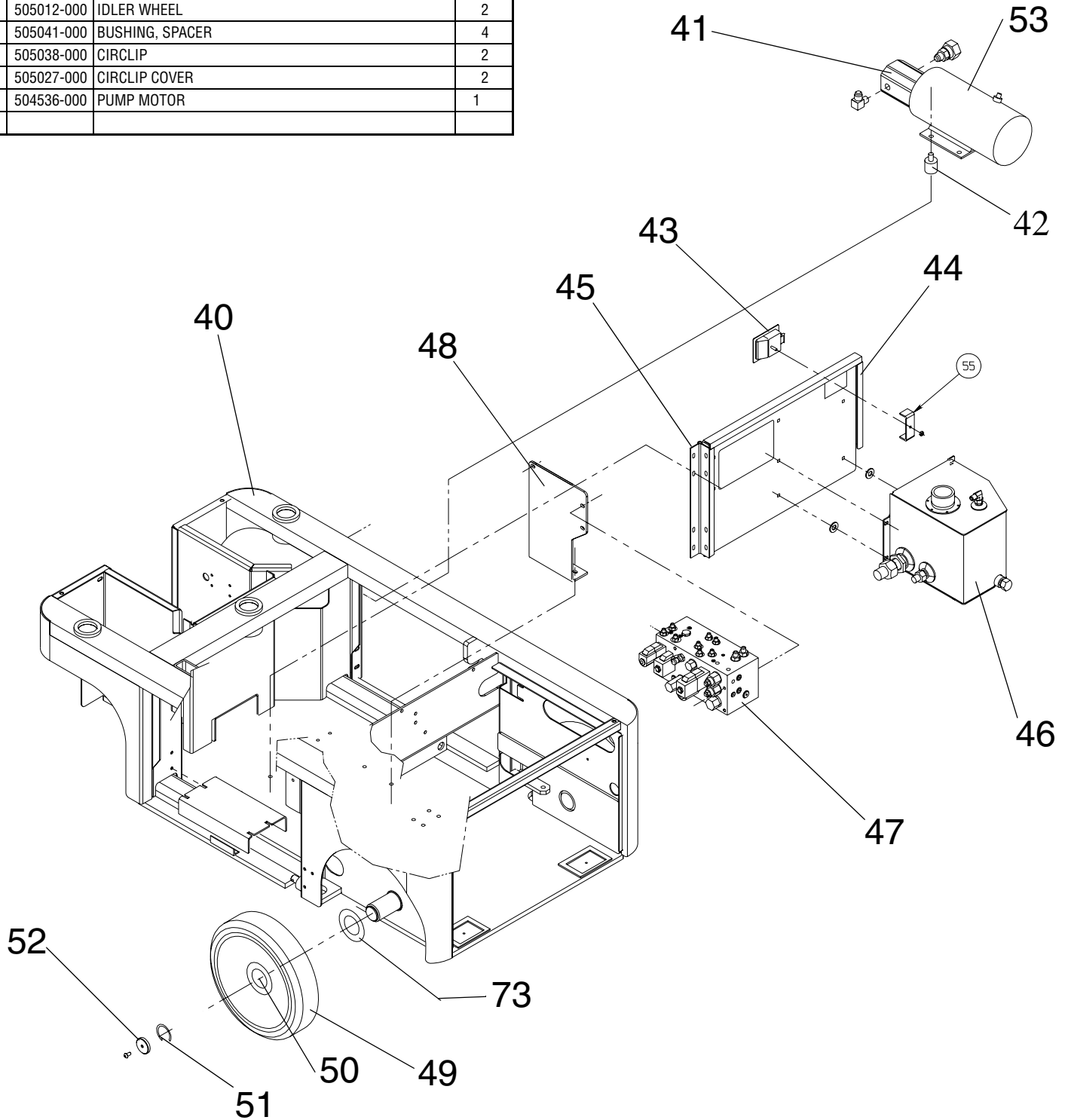

Chassis Assembly 4 of 4

505001-000

ITEM	PART NUMBER	DESCRIPTION	QTY
54	107179-000	POTHOLE WELDMENT-L.H.	1
55	107180-000	POTHOLE WELDMENT-R.H.	1
56	505036-000	HYDRAULIC CYLINDER, POTHOLE	2
-	505036-010	SEAL KIT, POTHOLE CYLINDER	-
57	011848-019	PIVOT PIN, POTHOLE CYL - CHASSIS	2
58	011848-036	PIVOT PIN, POTHOLE CYL - POTHOLE WELDMENT	2
59	N/A	N/A	N/A
60	502489-000	LINE CONTACTOR	1
61	N/A	N/A	N/A
62	058912-000	TILT SENSOR	1
63	057107-000	FILTER, HYDRAULIC	1
*	005154-002	FILTER ELEMENT	1
64	502483-000	ECU	1
65	502492-000	MOTOR CONTROLLER	1
66	N/A	MOUNTING PLATE	1
67	502588-000	ALARM SOUNDER	1
68	502286-000	MOUNTING POST, FUSE	2
69	502494-000	FUSE	1
70	107080-001	TIE DOWN RING (D-RING)	4
71	505091-000	BRACKET, POTHOLE TEE-PIECE MOUNT	1
72	505044-000	BUSHING, POTHOLE WELDMENT - CHASSIS	4

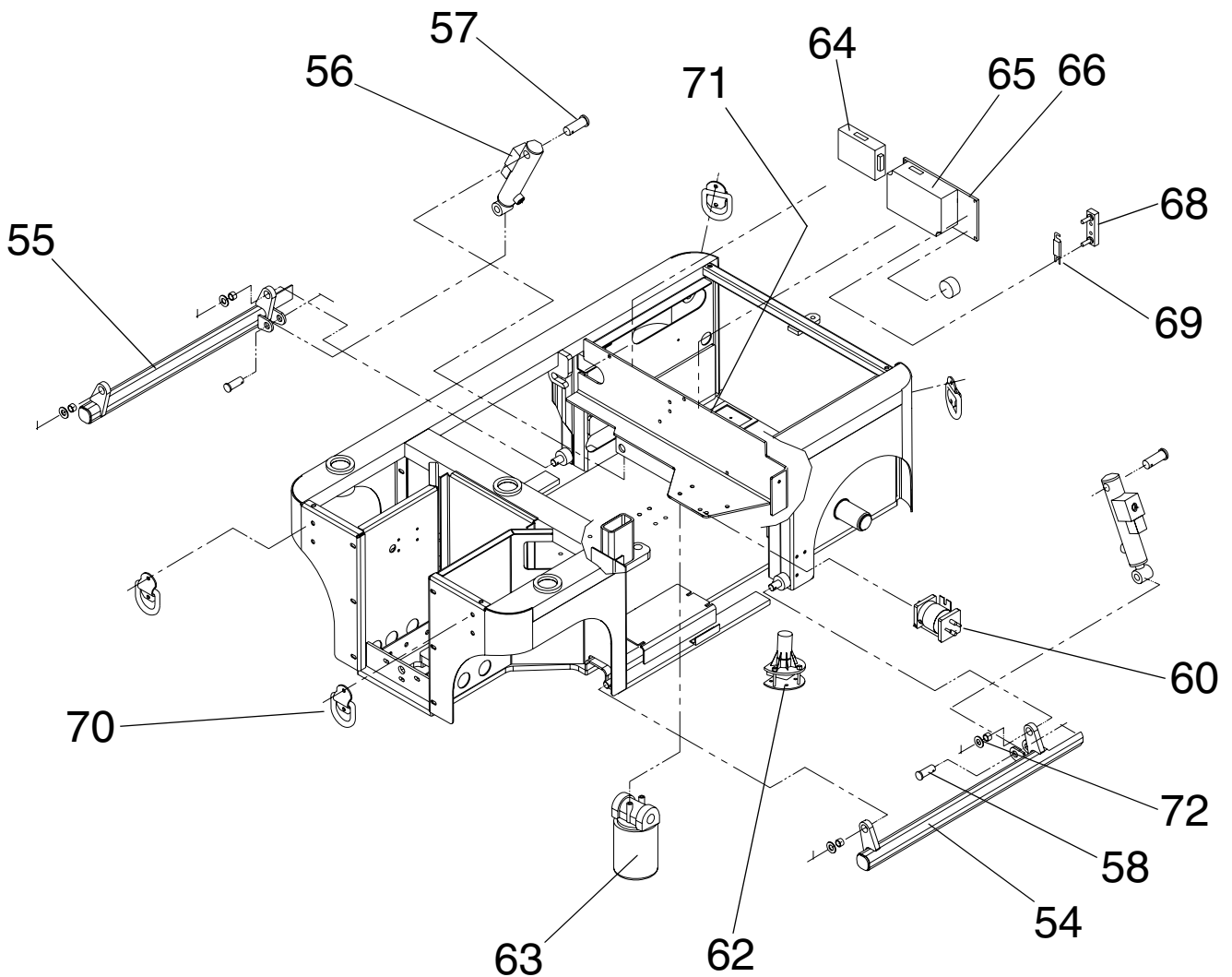

Illustrated Parts Breakdown - Mast Assembly

Mast Assembly

505002-000

Item	Part	Description	QTY.
1	505066-000	INNER MOUNT	2
2	505065-000	ANCHOR INNER	2
3	505073-000	STANDPIPE ADAPTER	1
4	505064-000	OUTER ANCHOR	1
5	505063-000	OUTER MOUNT	2
6	505057-000	OUTER AXLE	1
7	505056-000	INNER AXLE	1
8	065491-001	SECOND INNER MAST WEDMENT 4M	1
9	065488-001	LOWER INNER MAST WELDMENT	1
10	065485-004	BASE MAST WELDMENT	1
11	065450-001	CYL. BAR & PAD WELDMENT	1
12	505001-000	CHASSIS ASSY	1
13	505037-000	LIFT CYLINDER ASSY	1
*	505037-010	SEAL KIT, LIFT CYLINDER	REF
*	501483-000	EMERGENCY LOWERING VALVE	REF
14	505062-000	FRONT PAD	12
15	505061-000	REAR PAD	12
16	505060-000	PULLEY OUTER	1
17	505059-000	PULLEY INNER	1
18	505054-000	PIN	3
19	505055-000	ANCHOR PIN	2
20	505084-013	HEX HEAD SELF TAPPER (5.5 X 13)	36
21	501253-020	M6 X 20mm SOCKET HEAD CAP SCREW	18
22	505068-000	BEARING, 2220DU	4
23	505067-000	CHAIN LEAF, BL434 (103 LINKS)	4
24	065580-001	PLATFORM WELDMENT	REF
25	505072-000	SWITCH, PROXIMITY ASSY	1
26	501253-035	M6 X 35 SOCKET HEAD CAP SCREW	4
27	500532-035	M6 X 30 SOCKET HEAD COUNTERSUNK SCREW	2
28	056060-030	M10 X 30 SCREW (GRADE 12.9)	9
29	056060-025	M10 X 25 SCREW (GRADE 12.9)	2
30	056064-000	M10 NYLOCK NUT	11
31	056060-010	M10 WASHER	11

NOTE 1:
ITEMS 21, 26, 27, 28 & 29 MUST
BE GRADE 12.9 BOLTS.

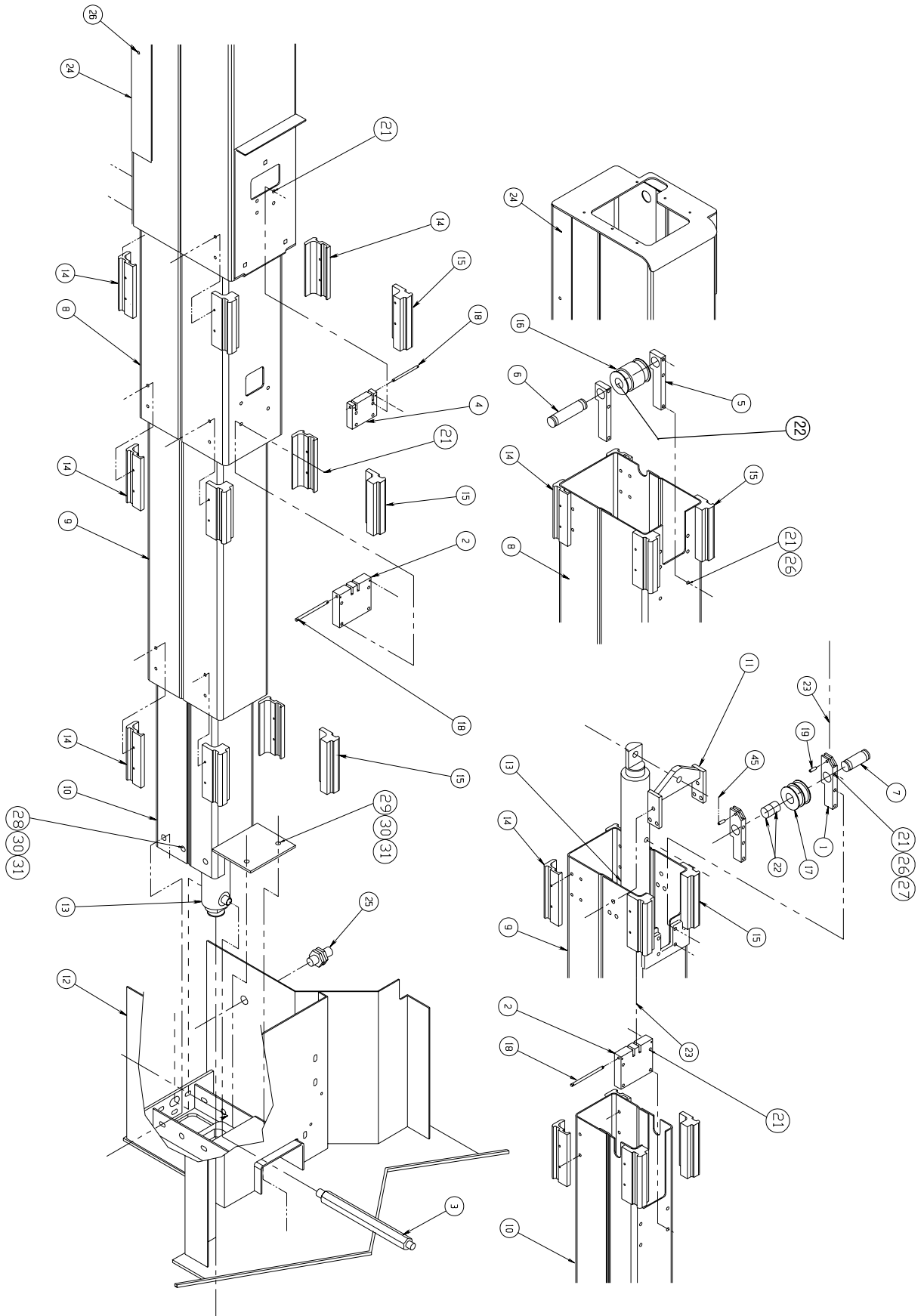

Illustrated Parts Breakdown - Platform Assembly

Platform Assembly

505003-000

Item	Part	Description	QTY.
1	505058-000	COVER PLATE (MAST TOP)	1
2	505005-000	UPPER CONTROLS ASSEMBLY	1
3	057094-000	HARDPOINT, SAFETY HARNESS	1
4	505010-000	DROP BAR ASSEMBLY	1
5	065580-001	PLATFORM WELDMENT	1
6	505069-000	TOEBOARD	1
7	107097-000	INSPECTION COVER	1

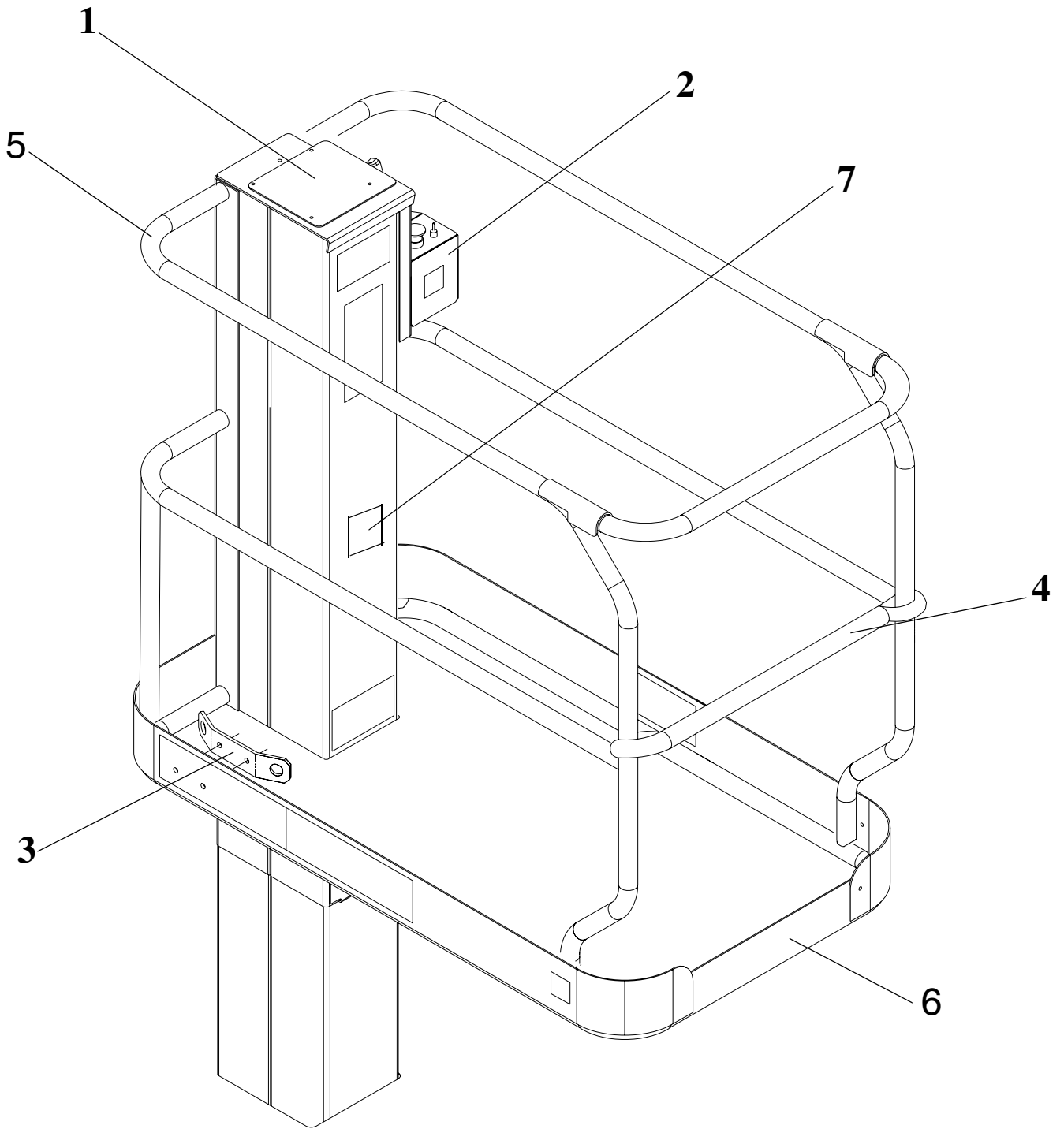

Illustrated Parts Breakdown - Control Valve Assembly

Control Valve Assembly

503800-000

Item	Part	Description	QTY.
1		TEST PORT	1
2	058358-000	FITTING, 1/4" - 1/4" MALE/MALE	1
3	058358-000	FITTING, 1/4" - 1/4" MALE/MALE	1
4	058358-000	FITTING, 1/4" - 1/4" MALE/MALE	1
5	057122-000	FITTING, 3/8" - 3/8" MALE/MALE	1
6	057122-000	FITTING, 3/8" - 3/8" MALE/MALE	1
7	058590-000	FITTING, 1/4 M/M ADAPTOR WITH 1mm OROFICE	1
8	057122-000	FITTING, 3/8" - 3/8" MALE/MALE	1
9	057358-000	FITTING, 1/4" - 1/4" MALE/MALE	1
10	N/A	N/A	N/A
11	057377-000	FITTING, 1/2" - 1/2" (MALE/MALE)	1
12	503802-000	CHECK VALVE, POTHOLE	1
13	503803-000	CROSS LINE RELIEF VALVE (DRIVE)	1
14	503804-000	VALVE, SOLENOID (DRIVE)	1
15	503805-000	VALVE, SOLENOID (DRIVE/LIFT)	1
16	503803-000	CROSS LINE RELIEF VALVE (DRIVE)	1
17	503807-000	PRESSURE RELIEF (MAIN LIFT)	1
18	503808-000	VALVE, SOLENOID (STEERING)	1
19	503809-000	FLOW RESTRICTOR (STEERING)	1
20	058728-000	RELIEF VALVE (STEERING)	1
21	057122-000	FITTING, 3/8" - 3/8" MALE/MALE	1
22	503810-000	RELIEF VALVE (MAIN RELIEF)	1
23	500303-000	COIL 18V	6

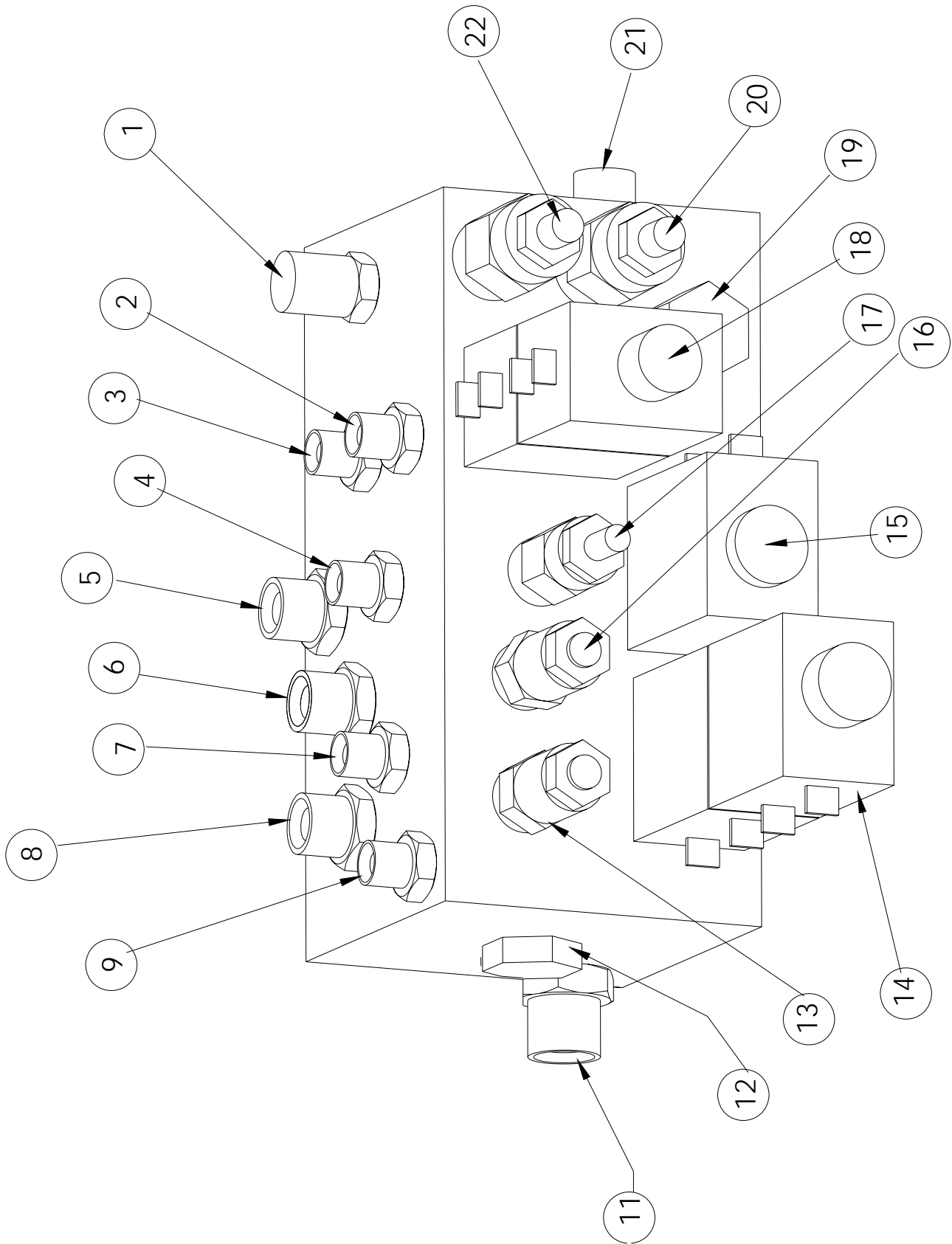

Lower Controls Assembly

505006-000

Item	Part	Description	QTY.
1	107148-000	LID, LCB BOX	1
2	505139-000	CABLE GLAND	1
3	107400-000	LCB BOX (WELDMENT)	1
4	502520-000	ENABLE BUTTON	1
5	502589-000	KEY SWITCH & MOUNT	1
6	502544-000	KEY	1
7	501867-000	EMERGENCY STOP BUTTON & MOUNT	1
8	058946-000	SWITCH BLOCK (N/O)	2
9	502251-000	TOGGLE SWITCH	1

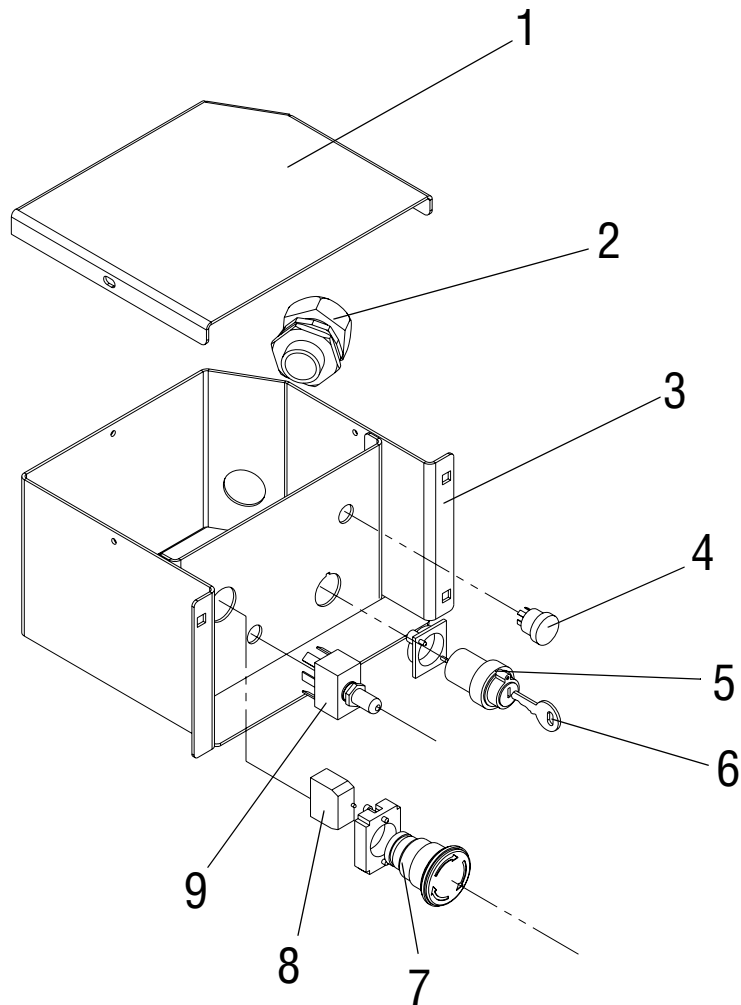

Hydraulic Tank Assembly

505013-000

Item	Part	Description	QTY.
1	057109-000	FILLER / BREATHER CAP	1
2	502196-000	SUCTION FILTER	1
3	503788-000	HYDRAULIC FITTING (3/4" M/M BSP)	1
4	503786-000	HYDRAULIC FITTING (1/2" M/M BSP)	1
5	503784-000	HYDRAULIC FITTING (1/8" M/M BSP)	1
6	057108-000	DRAIN PLUG (3/8")	1
7	505016-000	TANK WELDMENT	1

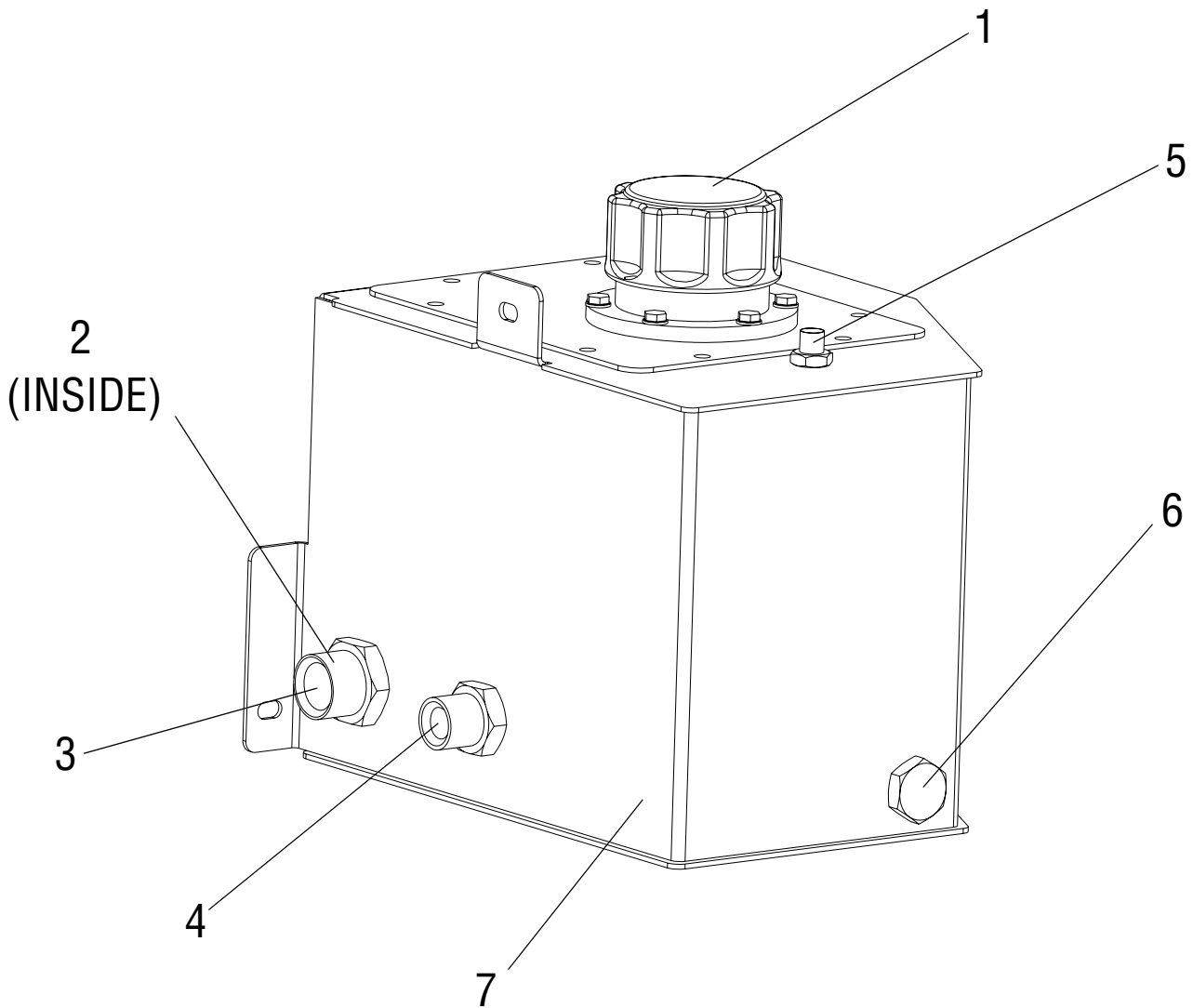

Upper Controls Assembly

505015-000

Item	Part	Description	QTY.
1	501882-000	JOYSTICK	1
*	501882-002	JOYSTICK RUBBER BOOT	1
*	501882-001	JOYSTICK STEERING BOOT	1
2	502511-000	OVERLAY	1
3	501592-000	MOUNTING PLATE	1
4	502591-000	SEAL	1
5	502453-000	PRINTED CIRCUIT BOARD	1
6	502529-000	UPPER CONTROL BOX (BOX ONLY)	1
7	501867-000	EMERGENCY STOP BUTTON ASSEMBLY	1

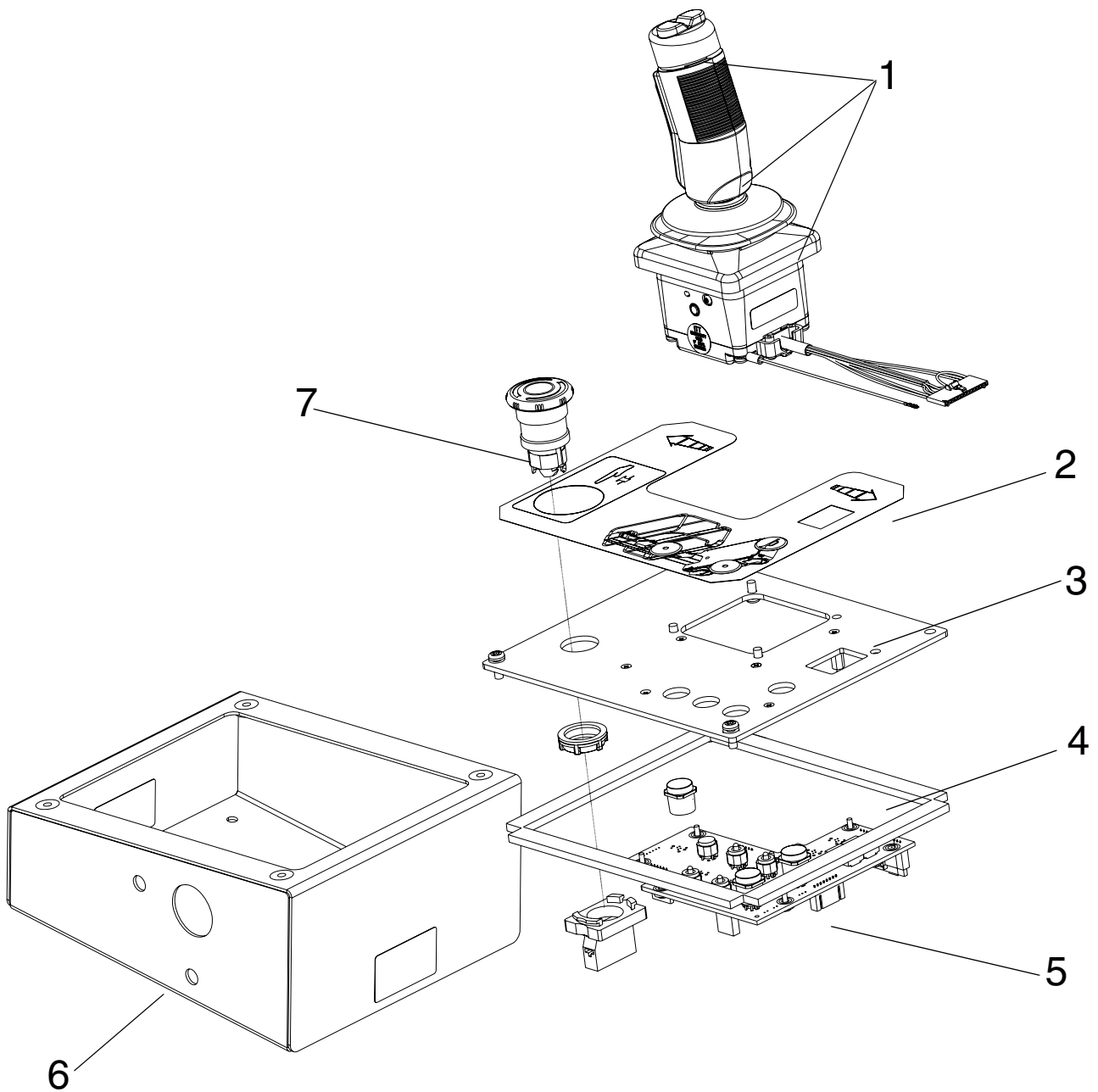

Notes :

Illustrated Parts Breakdown - Hydraulic Assembly

Hydraulic Assembly

(European Specification)

505007-000

Item	Part	Description	QTY.
1	501999-000	DRIVE MOTOR	2
2	N/A	N/A	N/A
3	505037-000	HYDRAULIC CYLINDER (LIFT)	1
4	505101-000	HYDRAULIC HOSE (MOTOR TO MOTOR)	1
5	505099-000	HYDRAULIC HOSE (BLOCK TO MOTOR, LH) DI - LH	1
6	505100-000	HYDRAULIC HOSE (BLOCK TO MOTOR, RH)D2 - RH	1
7	505108-000	HYDRAULIC HOSE (LIFT CYL DRAIN - TANK)	1
8	N/A	N/A	N/A
9	N/A	N/A	N/A
10	505098-000	HYDRAULIC HOSE (BLOCK TO MAIN LIFT CYL)	1
11	505035-000	HYDRAULIC CYLINDER, STEER / BRAKE	2
12	505118-000	HYDRAULIC HOSE(BLOCK - STEER CYL, FULL B)	1
13	505094-000	HYDRAULIC HOSE(BLOCK - STEER CYL, ANNULAR)	1
14	N/A	N/A	N/A
15	N/A	N/A	N/A
16	N/A	N/A	N/A
17	N/A	N/A	N/A
18	505104-000	HYDRAULIC HOSE (RETURN T - FILTER)	1

Item	Part	Description	QTY.
19	N/A	N/A	N/A
20	057107-000	FILTER (HYDRAULIC OIL)	1
21	N/A	N/A	N/A
22	505107-000	HYD HOSE (BLOCK - BRAKE CYL, ANNULAR)	1
23	503800-000	HYDRAULIC MANIFOLD BLOCK	1
24	505106-000	HYDRAULIC HOSE (DRAIN T - BRAKE FULL BORE)	1
25	505109-000	HYDRAULIC HOSE (DRAIN T - TANK)	1
26	505103-000	HYDRAULIC HOSE (PUMP - BLOCK, PRESSURE)	1
27	505102-000	HYDRAULIC HOSE (TANK - PUMP, SUCTION)	1
28	505095-000	HYDRAULIC HOSE (BLOCK - POTHOLE T-PIECE)	2
29	505105-000	HYDRAULIC HOSE (FILTER - TANK, RETURN)	1
30	505096-000	HYDRAULIC HOSE (TEE - POTHOLE CYL)	3
31	505097-000	HYDRAULIC HOSE (TEE - POTHOLE CYL)	1
32	503782-000	TEE PIECE (POTHOLE SYSTEM)	2
33	505036-000	HYDRAULIC CYLINDER (POTHOLE)	2
34	N/A	N/A	N/A
35	505013-000	TANK (HYDRAULIC RESERVOIR)	1
36	503782-000	TEE PIECE (CYL DRAIN)	1

Hydraulic Assembly

(U.S Specification) Serial Numbers 70000+

505007-001

Item	Part	Description	QTY.
1	501999-000	DRIVE MOTOR	2
2	N/A	N/A	N/A
3	N/A	N/A	N/A
4	505101-001	HYDRAULIC HOSE (MOTOR TO MOTOR)	1
5	505099-001	HYDRAULIC HOSE (BLOCK TO MOTOR, LH) DI - LH	1
6	505100-001	HYDRAULIC HOSE (BLOCK TO MOTOR, RH)D2 - RH	1
7	505108-001	HYDRAULIC HOSE (LIFT CYL DRAIN - TANK)	1
8	N/A	N/A	N/A
9	N/A	N/A	N/A
10	505098-001	HYDRAULIC HOSE (BLOCK TO MAIN LIFT CYL)	1
11	505035-000	HYDRAULIC CYLINDER, STEER / BRAKE	2
12	505118-001	HYDRAULIC HOSE(BLOCK - STEER CYL, FULL B)	1
13	505094-001	HYDRAULIC HOSE(BLOCK - STEER CYL, ANNULAR)	1
14	N/A	N/A	N/A
15	N/A	N/A	N/A
16	N/A	N/A	N/A
17	N/A	N/A	N/A
18	505104-001	HYDRAULIC HOSE (RETURN T - FILTER)	1

Item	Part	Description	QTY.
19	N/A	N/A	N/A
20	057107-000	FILTER (HYDRAULIC OIL)	1
21	N/A	N/A	N/A
22	505107-001	HYD HOSE (BLOCK - BRAKE CYL, ANNULAR)	1
23	503800-000	HYDRAULIC MANIFOLD BLOCK	1
24	505106-001	HYDRAULIC HOSE (DRAIN T - BRAKE FULL BORE)	1
25	505109-001	HYDRAULIC HOSE (DRAIN T - TANK)	1
26	505103-001	HYDRAULIC HOSE (PUMP - BLOCK, PRESSURE)	1
27	505102-001	HYDRAULIC HOSE (TANK - PUMP, SUCTION)	1
28	505095-001	HYDRAULIC HOSE (BLOCK - POTHOLE T-PIECE)	2
29	505105-001	HYDRAULIC HOSE (FILTER - TANK, RETURN)	1
30	505096-001	HYDRAULIC HOSE (TEE - POTHOLE CYL)	3
31	505097-001	HYDRAULIC HOSE (TEE - POTHOLE CYL)	1
32	503782-000	TEE PIECE (POTHOLE SYSTEM)	2
33	505036-000	HYDRAULIC CYLINDER (POTHOLE)	2
34	N/A	N/A	N/A
35	505013-000	TANK (HYDRAULIC RESERVOIR)	1
36	503782-000	TEE PIECE (CYL DRAIN)	1

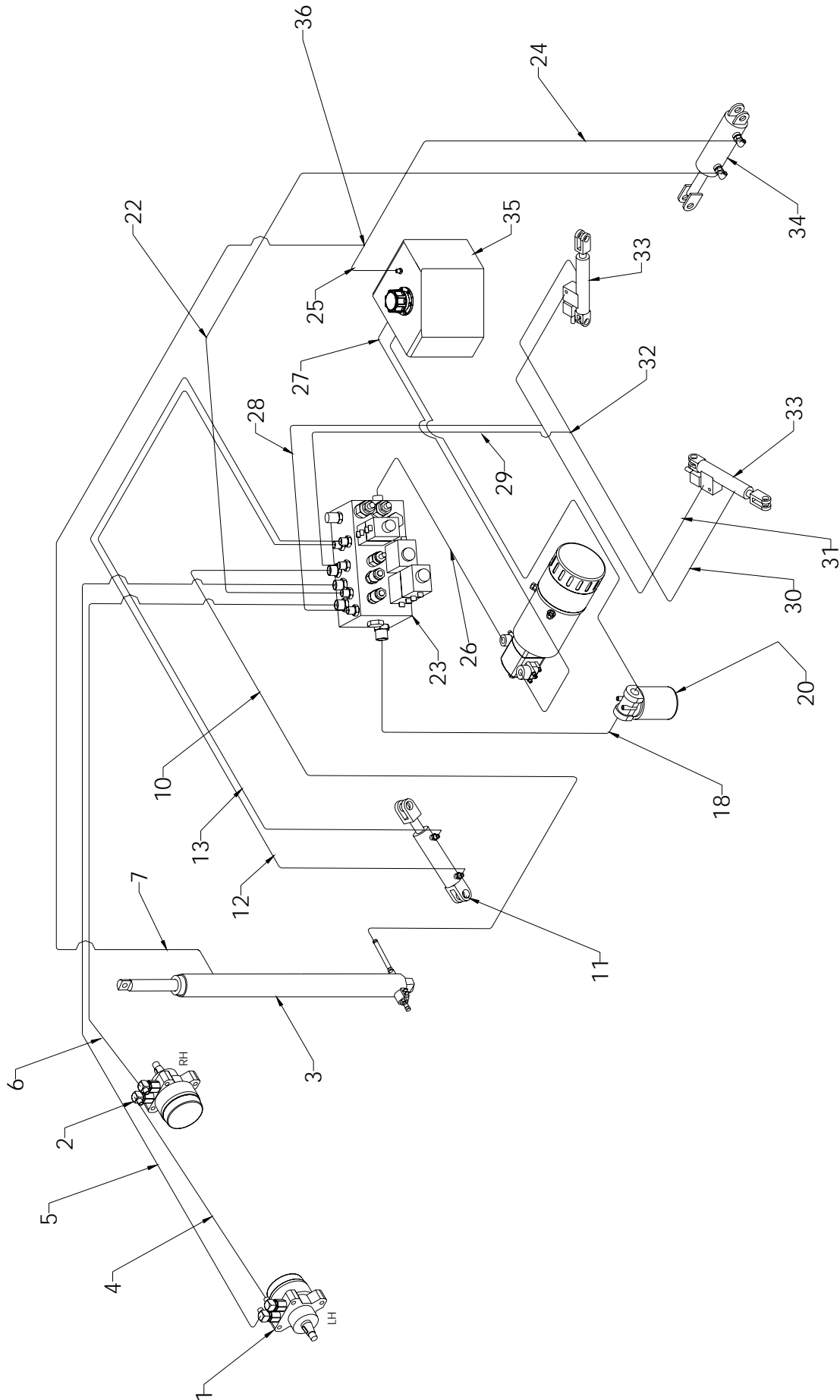

Hydraulic Schematic

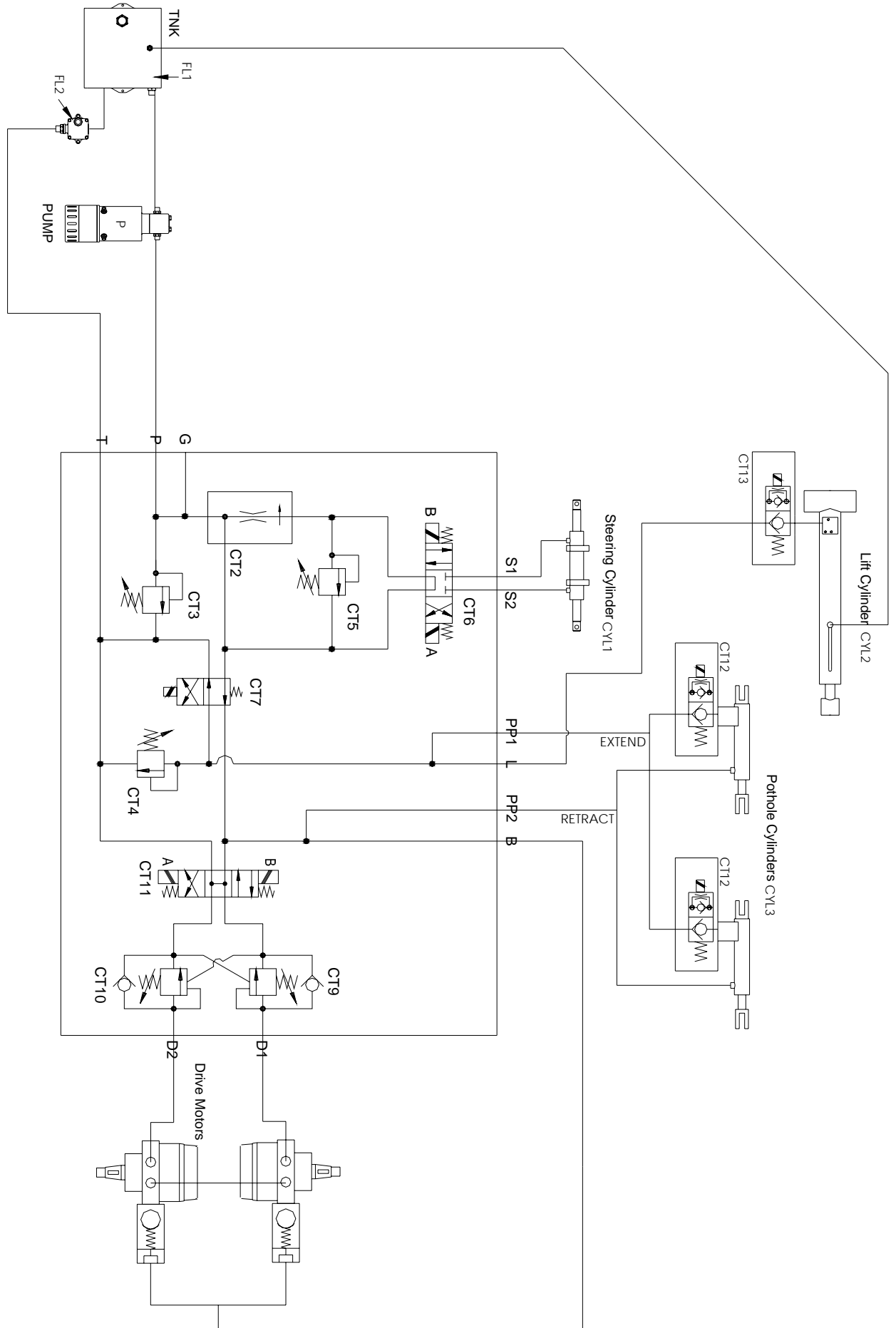

Hydraulic Cylinder Assembly (Lift)

505037-000

Item	Part	Description	QTY.
1	505037-010	LIFT CYLINDER SEAL KIT	1
2	505073-000	STANDPIPE ADAPTOR	1
3	501483-000	EMERGENCY DOWN VALVE	1
4	501483-001	ADAPTOR (EMERGENCY DOWN VALVE)	1

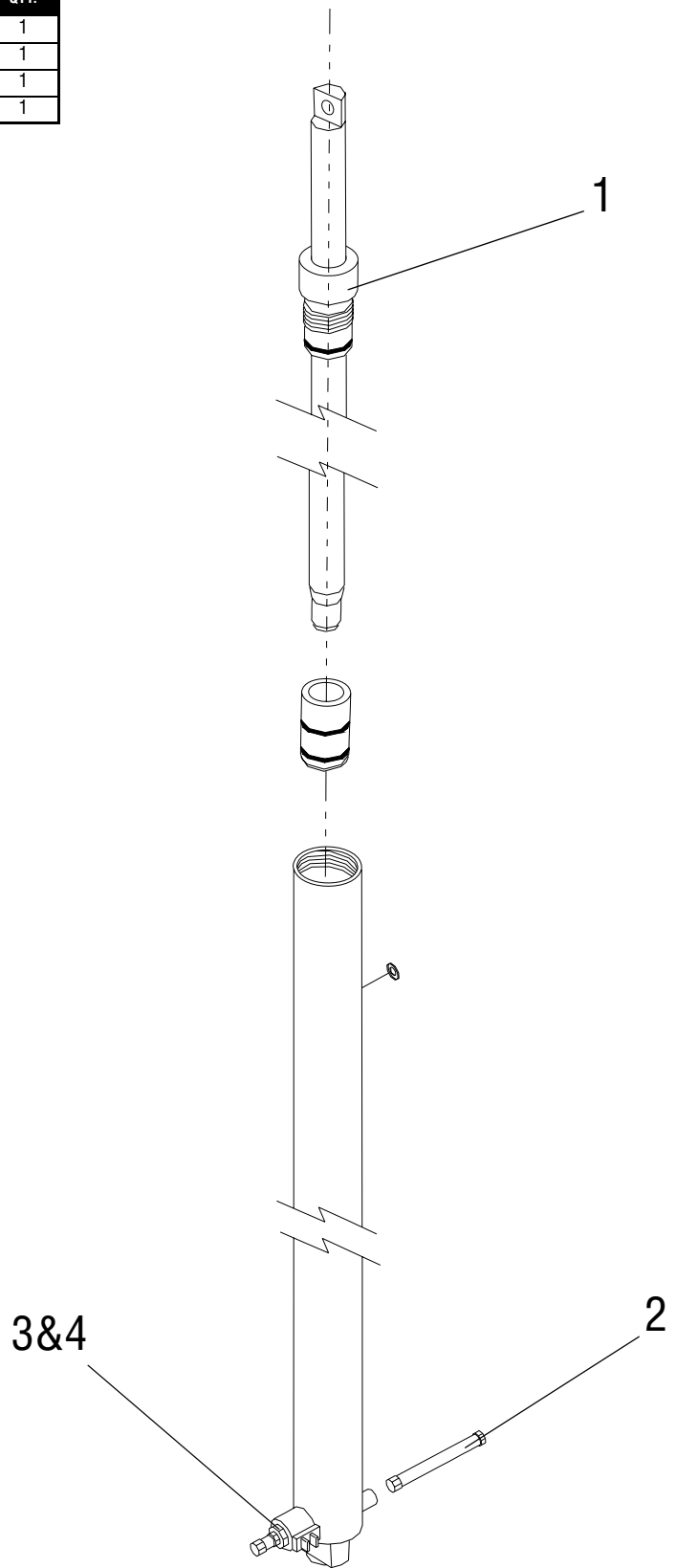

Hydraulic Cylinder Assembly (Steer / Brake)

505035-000

Item	Part	Description	QTY.
1	504502-010	SEAL KIT, BRAKE/STEER CYLINDER	1
2	503784-000	FITTING, 1/8 - 1/8 (M/M)	2
3	503783-000	FITTING, 1/8 M/F BLOCK 90	1

NOTE: FITTINGS SHOWN APPLY TO STEERING CYLINDER, WHEN FITTING HOSES TO THE BRAKE CYLINDER FIT THE 1/8 M/M TO THE FULL BORE END AND THE 1/8 BLOCK 90 WITH 1/8 M/M TO THE ANNULAR END.

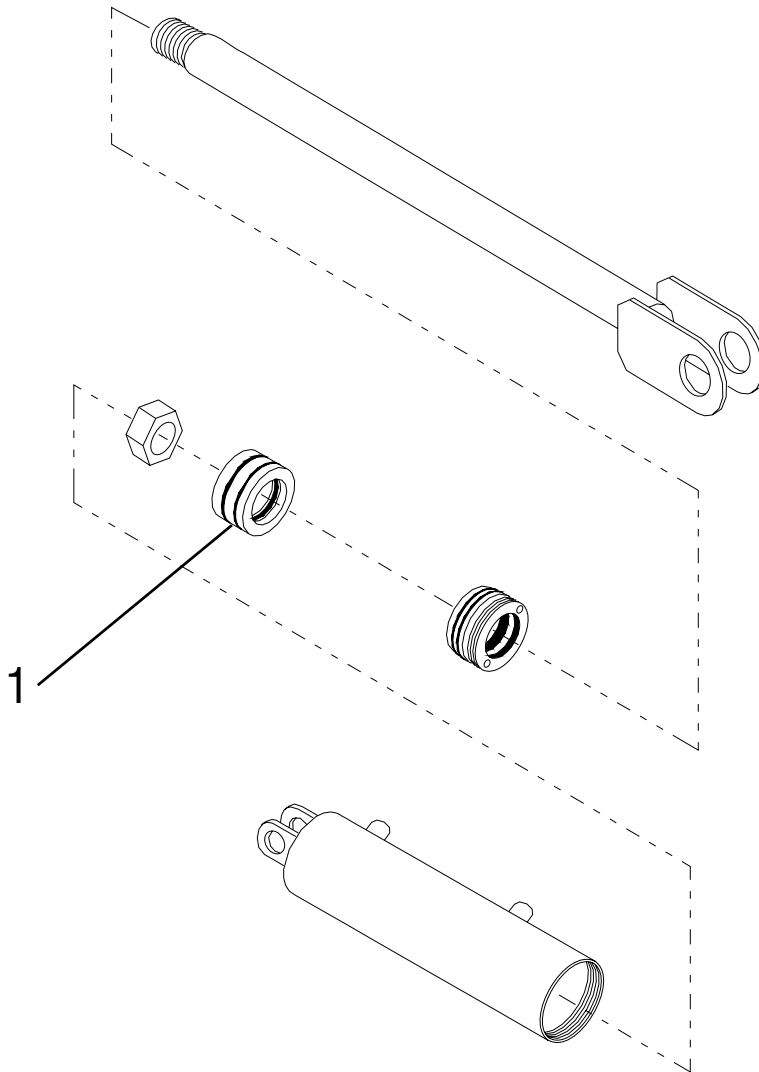
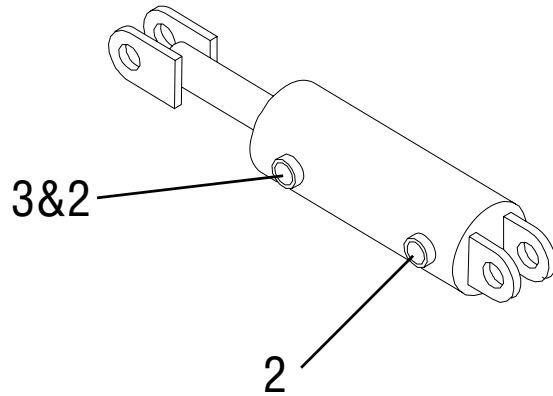

Hydraulic Cylinder Assembly (Pothole)

505036-000

Item	Part	Description	QTY.
1	505036-010	SEAL KIT, POTHOLE CYLINDER	1
2	501483-000	EMERGENCY RELEASE VALVE	1
*	501483-001	HANDLE (T-PIECE) EMERGENCY REL VALVE	1
3	503760-000	BUSHING	2
4	503785-000	FITTING, 1/4 - 1/8 (M/M)	1
5	503784-000	FITTING, 1/8 - 1/8 (M/M)	1

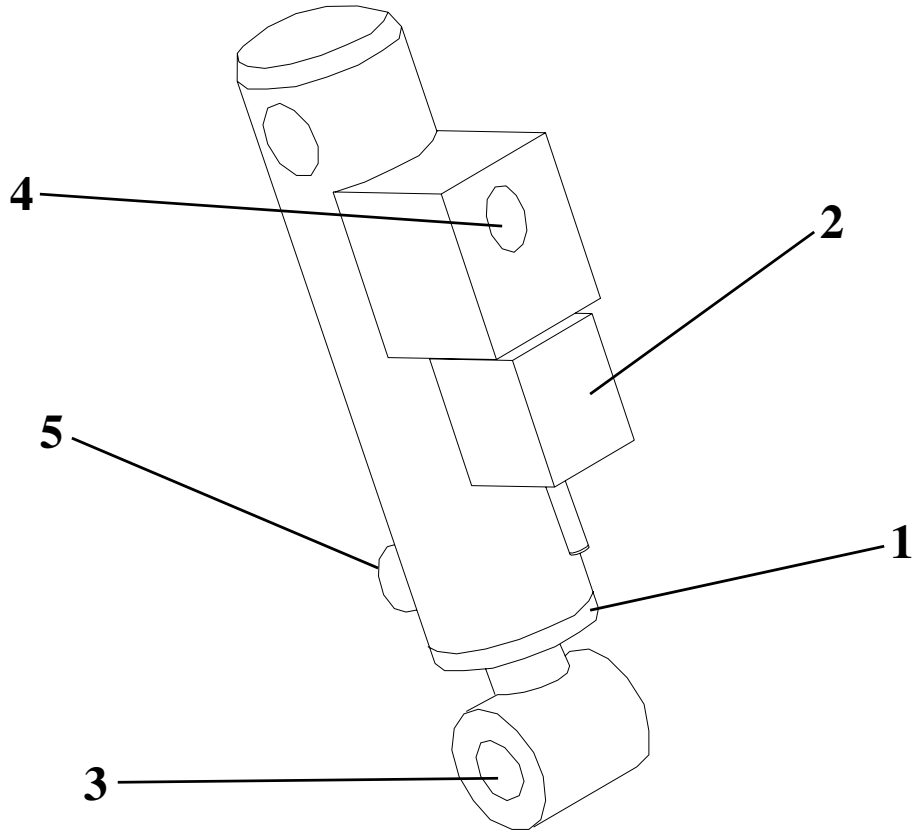

Illustrated Parts Breakdown - 32

Electrical Assembly

505008-000

Item	Part	Description	QTY.
1	502483-000	ECU	1
2	502593-000	J1 HARNESS	1
3	503800-001	MAIN MANIFOLD BLOCK	1
4	505015-000	UPPER CONTROLS	1
5	505006-000	LOWER CONTROLS	1
6	058912-000	TILT SENSOR	1
7	501868-000	HORN	1
8	502588-000	ALARM	1
9	505072-000	PROXIMITY SENSOR	1
10	502494-000	FUSE	1
11	058937-000	BATTERY DISCONNECT PLUG	1
12	502594-000	HARNESS, BATTERY DISCONNECT - BATT (-)	1
13	502595-000	HARNESS, BATTERY DISCONNECT - BATT (+)	1
14	501074-000	BATTERY	4

Item	Part	Description	QTY.
15	502596-000	HARNESS, BATTERY INTERCONNECT	3
16	069199-001	CHARGER	1
17	058783-000	CHARGER DISCONNECT PLUG	1
18	502597-000	HARNESS, CHARGER DISCONNECT (+) - LINE CON4	1
19	502598-000	HARNESS, CHARGER DISCONNECT (-) - BATT (-)	1
20	502599-000	HARNESS, CHARGER DISCONNECT (-) - LINE CON2	1
21	502600-000	LINE CONTACTOR 3 - FUSE	1
22	502601-000	LINE CONTACTOR 5 - LINE CONTACTOR 3	1
23	502489-000	LINE CONTACTOR	1
24	502602-000	LINE CONTACTOR 2 - MOTOR CONT B-	1
25	502603-000	LINE CONTACTOR 1 - MOTOR CONT ENABLE	1
26	502604-000	LINE CONTACTOR 6 - PUMP MOTOR	1
27	502492-000	MOTOR CONTROLLER	1
28	114071-000	PUMP MOTOR	1

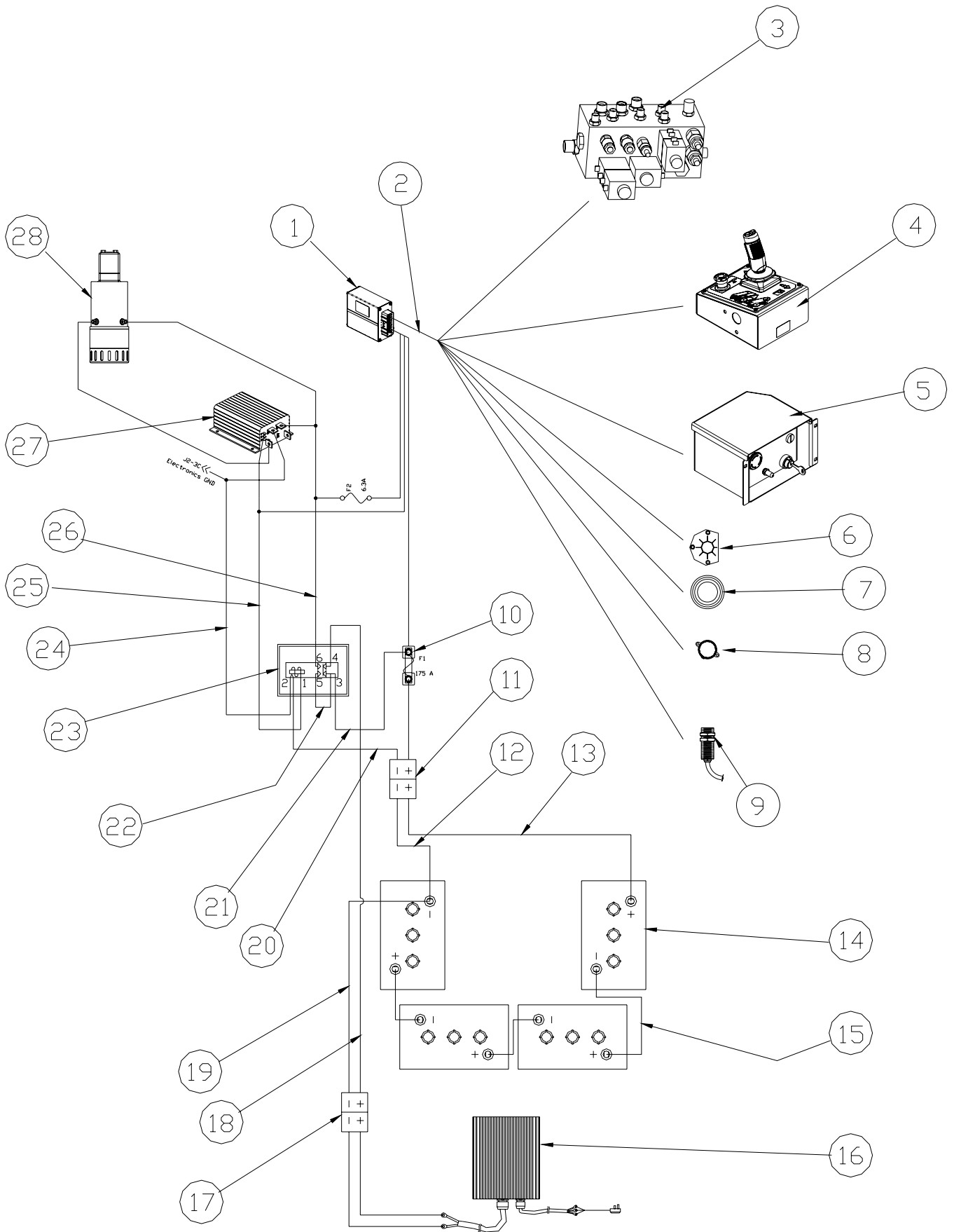

Label Kit, European (English)

505004-000

Item	Part	Description	QTY.
1	060197-001	DECAL, HYDRAULIC FLUID	1
2	101210-000	DECAL, HYDROGEN GAS	1
3	005223-909	DECAL, EMERGENCY DOWN	1
4	502511-000	DECAL, UPPER CONTROLS	1
5	107052-000	DECAL, SAFE WORKING LOAD	1
6	010076-901	DECAL, DOCUMENTS ENCLOSED	1
7	505079-000	DECAL, LOWER CONTROLS	1
8	062562-951	DECAL, BATTERIES ARE BALLAST	1
9	505076-000	DECAL, THREE HAZARDS	1
10	014222-903	DECAL, FORKLIFT POINT	2
11	100102-900	DECAL, NOT INSULATED	1
12	066522-900	DECAL, BATTERY SYMBOL	1
13	068635-001	DECAL, HARNESS HARDPOINT	1
14	501453-000	DECAL, WARNING (FOOT CRUSH)	2
15	503723-000	DECAL, BATTERY DISCONNECT	1
16	107053-000	DECAL, HORN	1
17	505077-000	DECAL, "UpRight TM12"	2

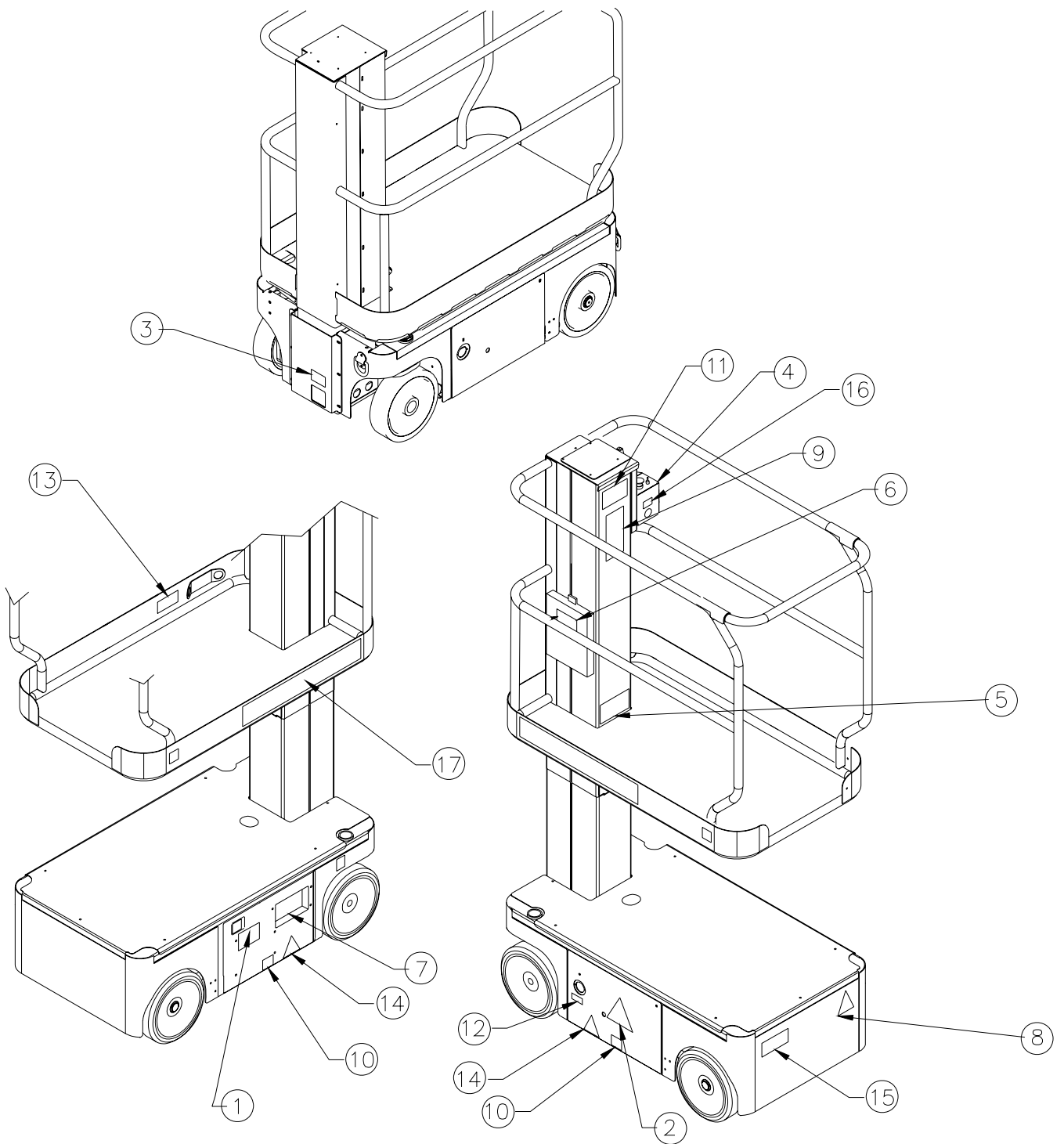

Label Kit, German

505004-200

Item	Part	Description	QTY.
1	060197-001	DECAL, HYDRAULIC FLUID	1
2	101210-000	DECAL, HYDROGEN GAS	1
3	005223-909	DECAL, EMERGENCY DOWN	1
4	502511-000	DECAL, UPPER CONTROLS	1
5	107052-000	DECAL, SAFE WORKING LOAD	1
6	010076-901	DECAL, DOCUMENTS ENCLOSED	1
7	505079-000	DECAL, LOWER CONTROLS	1
8	062562-951	DECAL, BATTERIES ARE BALLAST	1
9	505076-200	DECAL, THREE HAZARDS	1
10	014222-903	DECAL, FORKLIFT POINT	2
11	100102-900	DECAL, NOT INSULATED	1
12	066522-900	DECAL, BATTERY SYMBOL	1
13	068635-001	DECAL, HARNESS HARDPOINT	1
14	501453-000	DECAL, WARNING (FOOT CRUSH)	2
15	503723-000	DECAL, BATTERY DISCONNECT	1
16	107053-000	DECAL, HORN	1
17	505077-000	DECAL, "UpRight TM12"	2

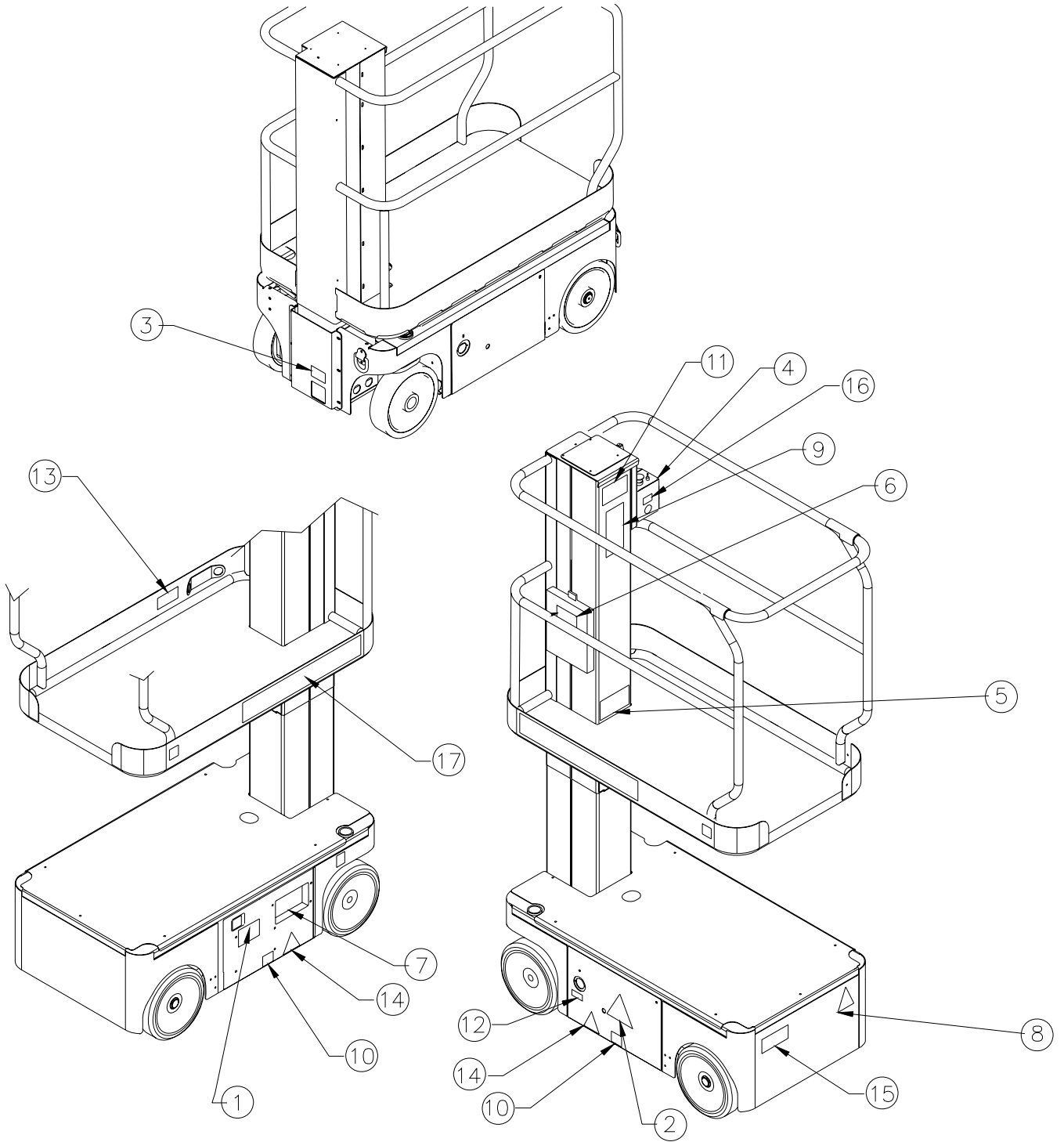

Label Kit, French

505004-300

Item	Part	Description	QTY.
1	060197-001	DECAL, HYDRAULIC FLUID	1
2	101210-000	DECAL, HYDROGEN GAS	1
3	005223-909	DECAL, EMERGENCY DOWN	1
4	502511-000	DECAL, UPPER CONTROLS	1
5	107052-000	DECAL, SAFE WORKING LOAD	1
6	010076-901	DECAL, DOCUMENTS ENCLOSED	1
7	505079-000	DECAL, LOWER CONTROLS	1
8	062562-951	DECAL, BATTERIES ARE BALLAST	1
9	505076-300	DECAL, THREE HAZARDS	1
10	014222-903	DECAL, FORKLIFT POINT	2
11	100102-900	DECAL, NOT INSULATED	1
12	066522-900	DECAL, BATTERY SYMBOL	1
13	068635-001	DECAL, HARNESS HARDPOINT	1
14	501453-000	DECAL, WARNING (FOOT CRUSH)	2
15	503723-000	DECAL, BATTERY DISCONNECT	1
16	107053-000	DECAL, HORN	1
17	505077-000	DECAL, "UpRight TM12"	2

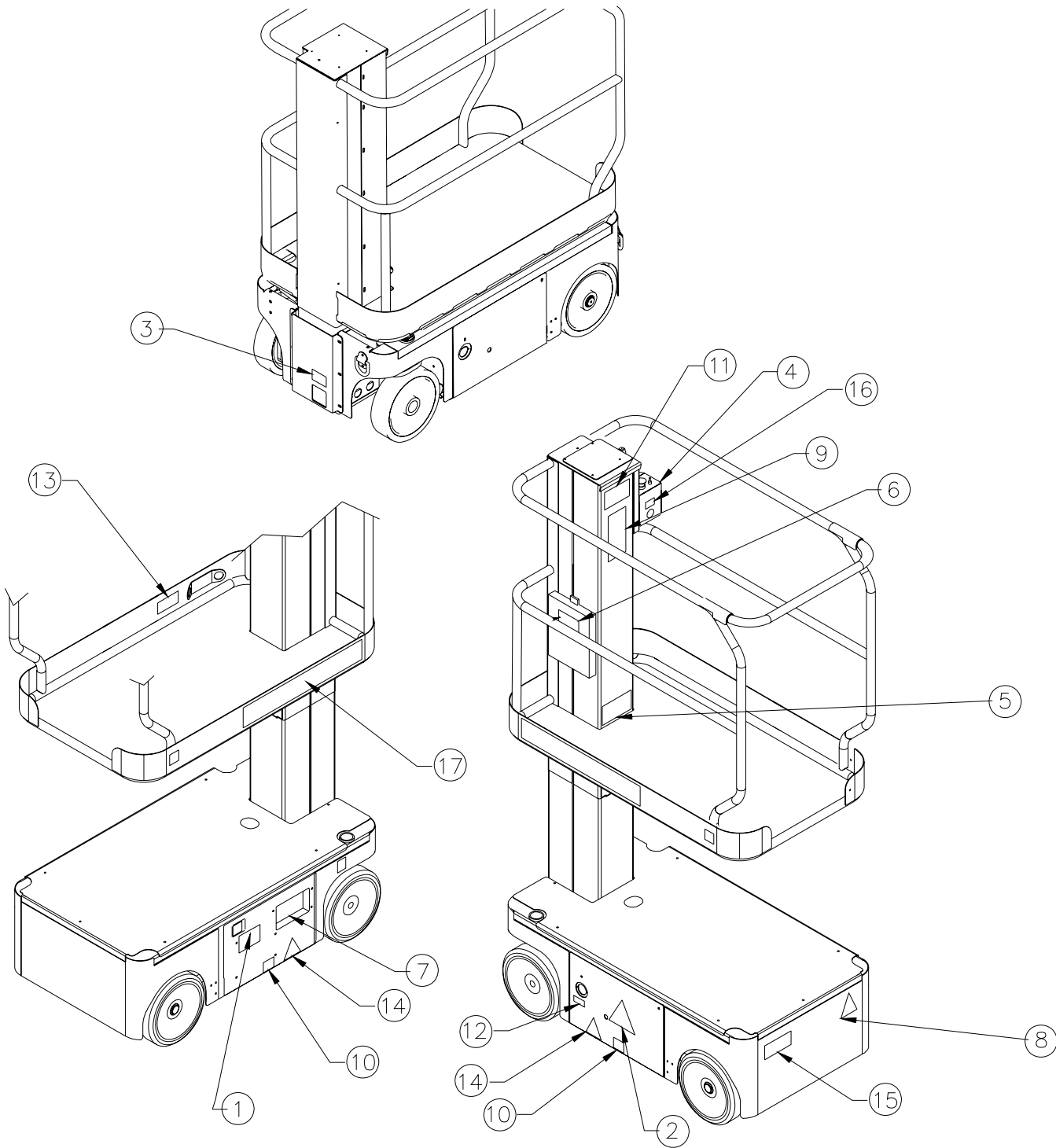

Illustrated Parts Breakdown - Label Kit, USA

Label Kit, USA

Serial Numbers 70000+

107012-010

Item	Part	Description	QTY.
1	060197-000	DECAL, HYDRAULIC OIL	1
2	066552-000	DECAL, HYDROGEN GAS	1
3	061205-005	NAME PLATE	1
4	N/A	N/A	N/A
5	005221-000	DECAL, BATTERY FLUID	1
6	005221-005	DECAL, EMERGENCY DOWN	1
7	066554-000	DECAL, BEFORE OPERATING	1
8	107050-000	DECAL, CONTROLLER	1
9	061683-003	DECAL, UPRIGHT	2
10	101250-000	DECAL, MAX LOAD 500lbs	3
11	061684-014	DECAL, TM12	2
12	N/A	N/A	N/A
13	010076-001	DECAL, ATTENTION	1
14	N/A	N/A	N/A
15	065568-001	DECAL, CONTROLS	1
16	N/A	N/A	N/A
17	N/A	N/A	N/A
18	064444-000	DECAL, USA	3
19	062562-001	DECAL, BATTERIES	1
20	066550-001	DECAL, DANGER	1
21	14222-003-99	DECAL, FORK LIFT	2
22	061220-002	DECAL, ANSI	1
23	066555-000	DECAL, RELIEF VALVE	1
24	066568-000	DECAL, LOWER PLATFORM	1
25	066556-000	DECAL, COLLISION HAZARD	3
26	066522-000	DECAL, BATTERY CHARGER	1
27	101252-000	DECAL, MAX WHEEL LOAD (675lbs)	1
28	066556-001	DECAL, WARNING	2
29	107051-000	DECAL, BATTERY DISCONNECT	1

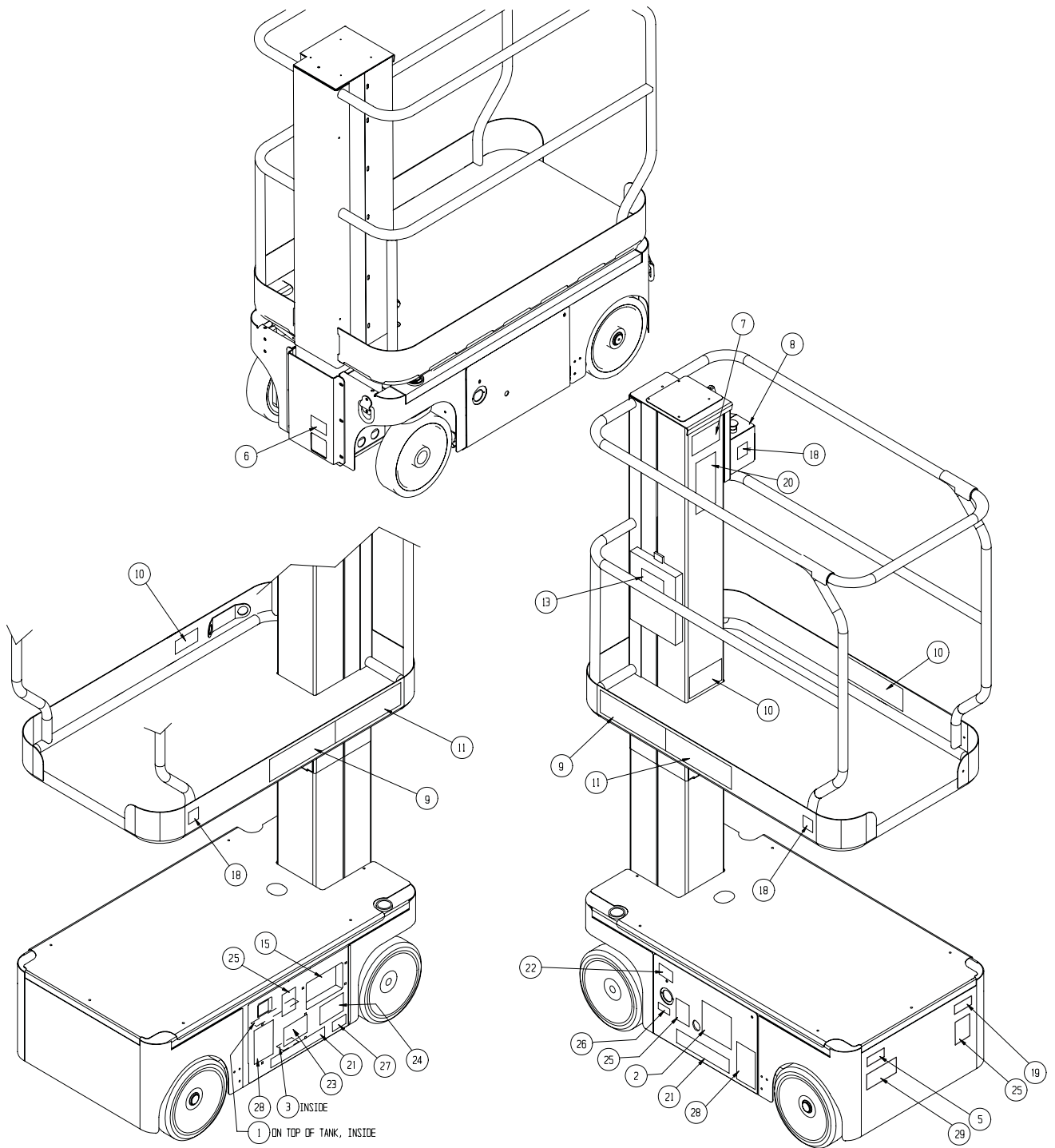

Local Distributor:

Lokaler Vertiebshändler:

Distributeur local:

El Distribuidor local:

Il Distributore locale:

USA

TEL: +1 (559) 443 6600
FAX: +1 (559) 268 2433

UpRight
POWERED ACCESS

www.upright.com

Europe

TEL: +44 (0) 845 1550 058